

Heritage Quilters of Huntsville

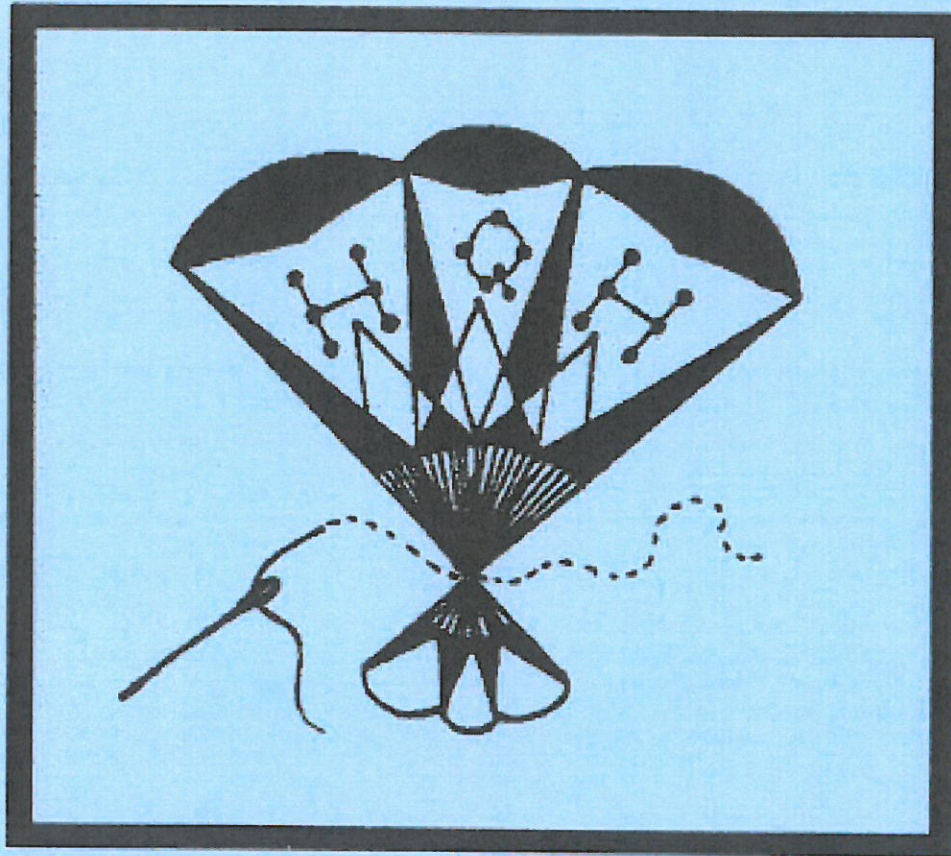

**Block of the Month,
Series Quilt and
Mystery Quilts
1988-2000**

**Plus 2011 Mystery Quilt
and 2012 Anniversary BOM**

This volume is a compilation of the HQH block of the month patterns, series quilt patterns and mystery quilt patterns from the Guild's inception in 1988 through 2000. Most patterns have appeared in the newsletter, but some were given out at monthly meetings. Firstly, thanks to all those who have generously shared their talents with the Guild in this way over the years. Thanks also to those who have held onto older patterns and selflessly helped to put this together: Ellen Anson, Barbara Black, Claire Davies, Kim Hamby, and Judy Servick. Feel free to make copies of these patterns for your personal use and as always, remember to return it to the Guild Library so that others may enjoy it as well.

Guild Librarian
2004/2005
Sharon Suever

HERITAGE QUILTERS OF HUNTSVILLE

When Donna Fahey and I joined up to be co-librarians in 2014/2015, we were overwhelmed by the number of quilting books and DVDs that were available for use by members. There were pattern books, techniques, history, fiction ... you name it and it was on the shelves. But we were totally captivated by this book of past HQH BOM's and mystery quilts! We thought it would be great to make it available via pdf, and in doing so, added the 2011 Mystery Quilt that was designed by Sharon Suever and Deanna Plots, and the very special 2011/2012 25th Anniversary BOM that was designed by Bonnie Spencer. We hope that by putting all of these wonderful patterns in electronic format, they'll be able to be enjoyed and used by many more guild members.

Guild Librarians
2014/2015
Donna Fahey and Denise Panter

*27.00

HQH Block of the Month, Series Quilts and Mystery Quilts 1988 to 2000

1988/1989 Block of the Month

12" appliquéd and pieced blocks
September 1988 thru August 1989
designed by Linda Worley

1989/1990 Block of the Month

Baltimore Album style 16" blocks
September 1989 thru August 1990
designed by Kim Hamby

1990/1991 Block of the Month

Nine Patch Plus: 9" blocks
September 1990 thru August 1991
designed by Ellen Anson

1991/1992 Block of the Month

12" pieced star blocks
September 1991 thru August 1992
designed by Linda Worley

1992/1993 Series Quilt

Tulip appliquéd quilt
September 1992 thru August 1993
designed by Ellen Anson

1993/1994 Mystery Quilt

"Mystery! A Scrappy Surprise"
September 1993 thru February 1994
designed by Judy Hopkins and
Barbara Black

1994 Series Quilt

Fan Series Quilt
March 1994 thru August 1994
designed by Carol Strong

1994/1995 Block of the Month

"The Year of the Mini's" 4" blocks
September 1994 thru August 1995
designed by Judy Servick

1995/1996 Block of the Month

Applique blocks sized from 7 1/2 to 8"
September 1995 thru August 1996
designed by Linda Worley

1996/1997 Block of the Month

Holiday themed blocks measuring 8"
September 1996 thru August 1997
designed by Elma Bartholomew

1997/1998 Block of the Month

Pieced and appliquéd basket blocks
measuring 8 1/2"
September 1997 thru August 1998
designed by Nina Antonison and
Claire Davies

1998/1999 Series Quilt

"Summertime" series quilt
September 1998 thru August 1999
designed by Ellen Anson

1999/2000 Mystery Quilt

"Garden Party" copywrited by Tyanne
Agle and printed with permission.
September 1999 thru August 2000
Facilitated by Jo Reid and
Nina Antonison

E-Pub Bonus: 2010—2012

2010/2011 Mystery Quilt

9" pieced blocks
January 2011 thru June 2011
designed by Sharon Suever and
Deanna Plotts

2011/2012 25th Anniversary Block of the Month

10" pieced blocks
September 2011 thru August 2012
designed by Bonnie Spencer

Heritage Quilters of Huntsville

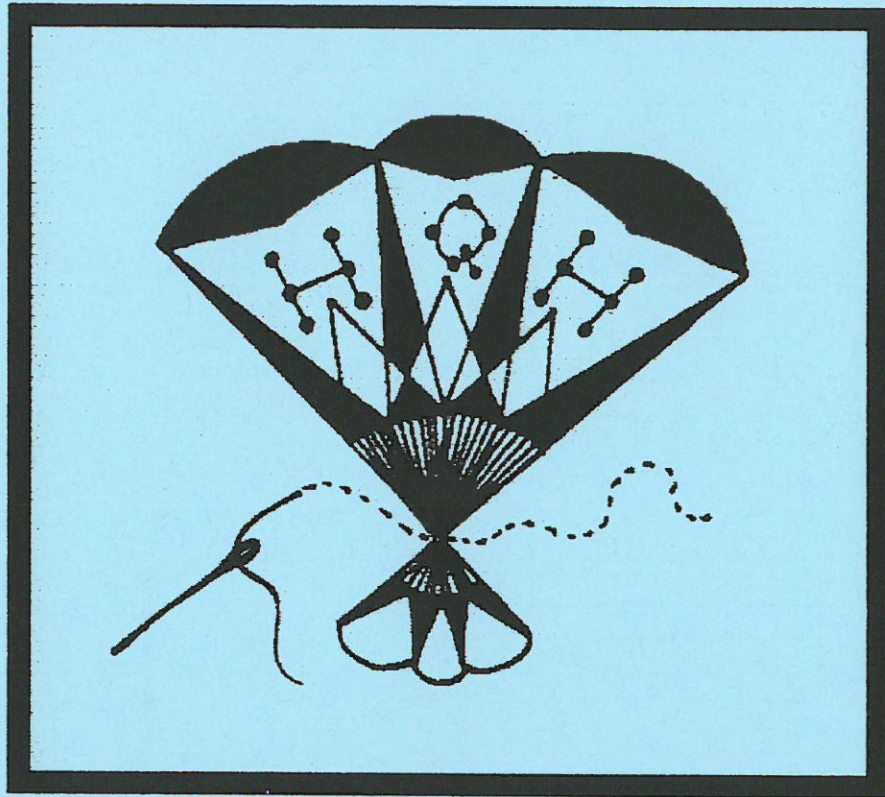

Block of the Month Patterns

1988/1989

**12" appliquéd and pieced blocks
designed by
Linda Worley**

SEPTEMBER TEACHER'S APPLE

- 12" pieced and applique quilt block
- Add $\frac{1}{4}$ " seam allowance

Cut strips $1\frac{1}{2}$ " wide
(includes $\frac{1}{4}$ " seam allowance)

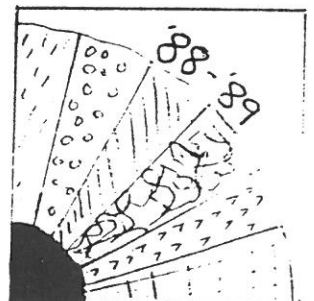
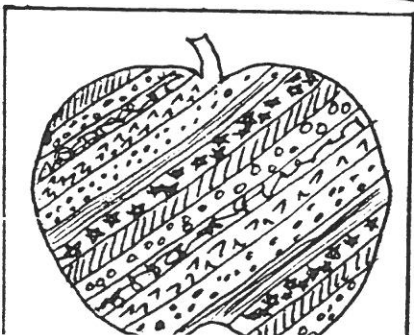

HERITAGE
QUILTERS

OCTOBER

MAPLE LEAF

- 12" pieced quilt block
- Add 1/4" seam allowance

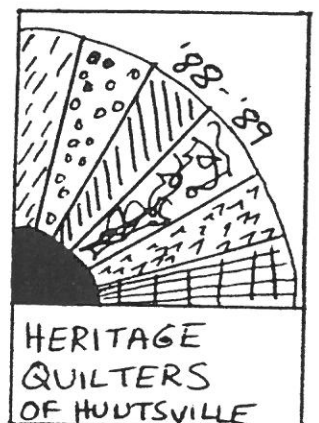
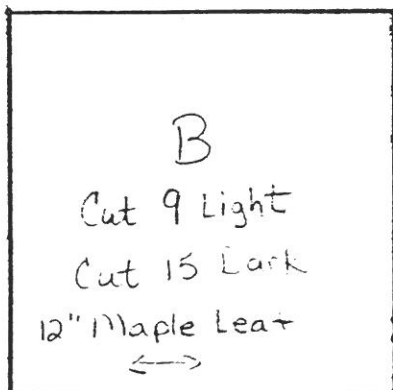
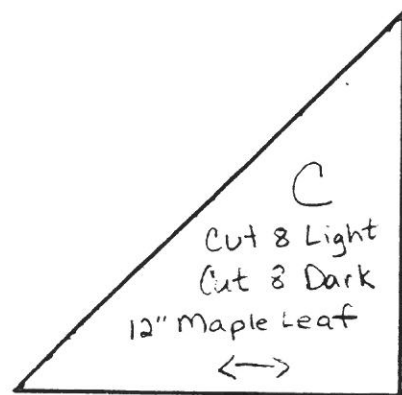
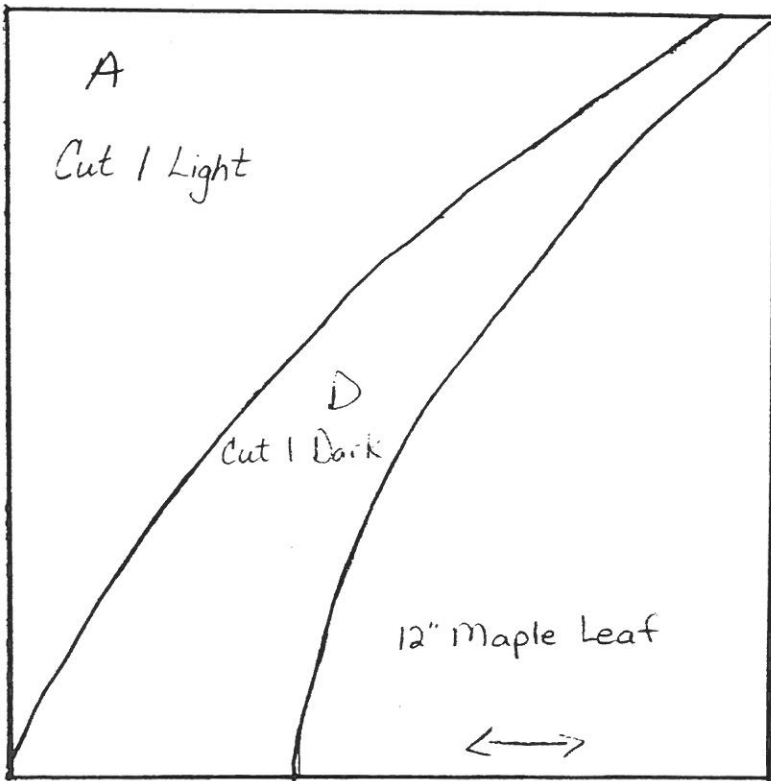
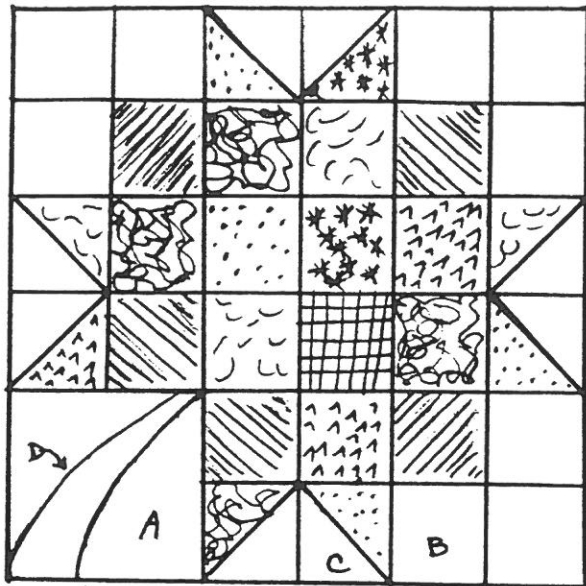

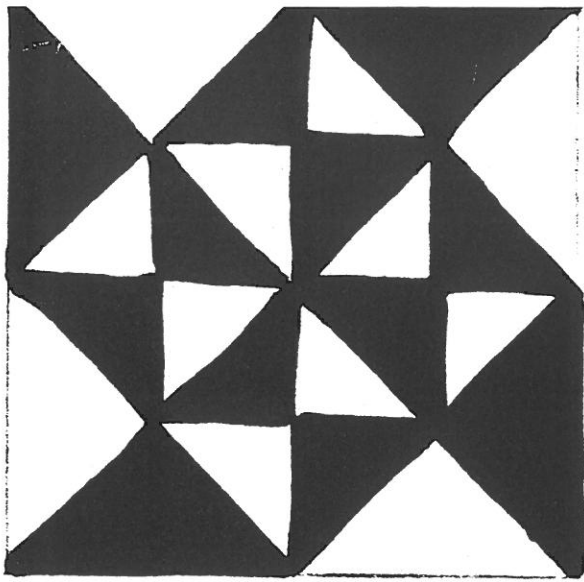

NOVEMBER PEACE AND PLENTY

- 12" pieced quilt block
- Add 1/4" seam allowances

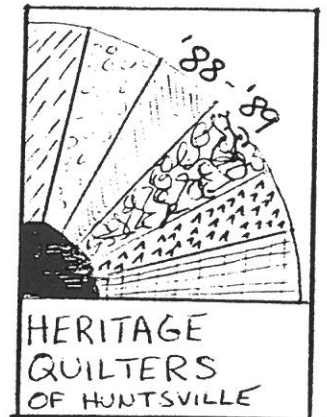
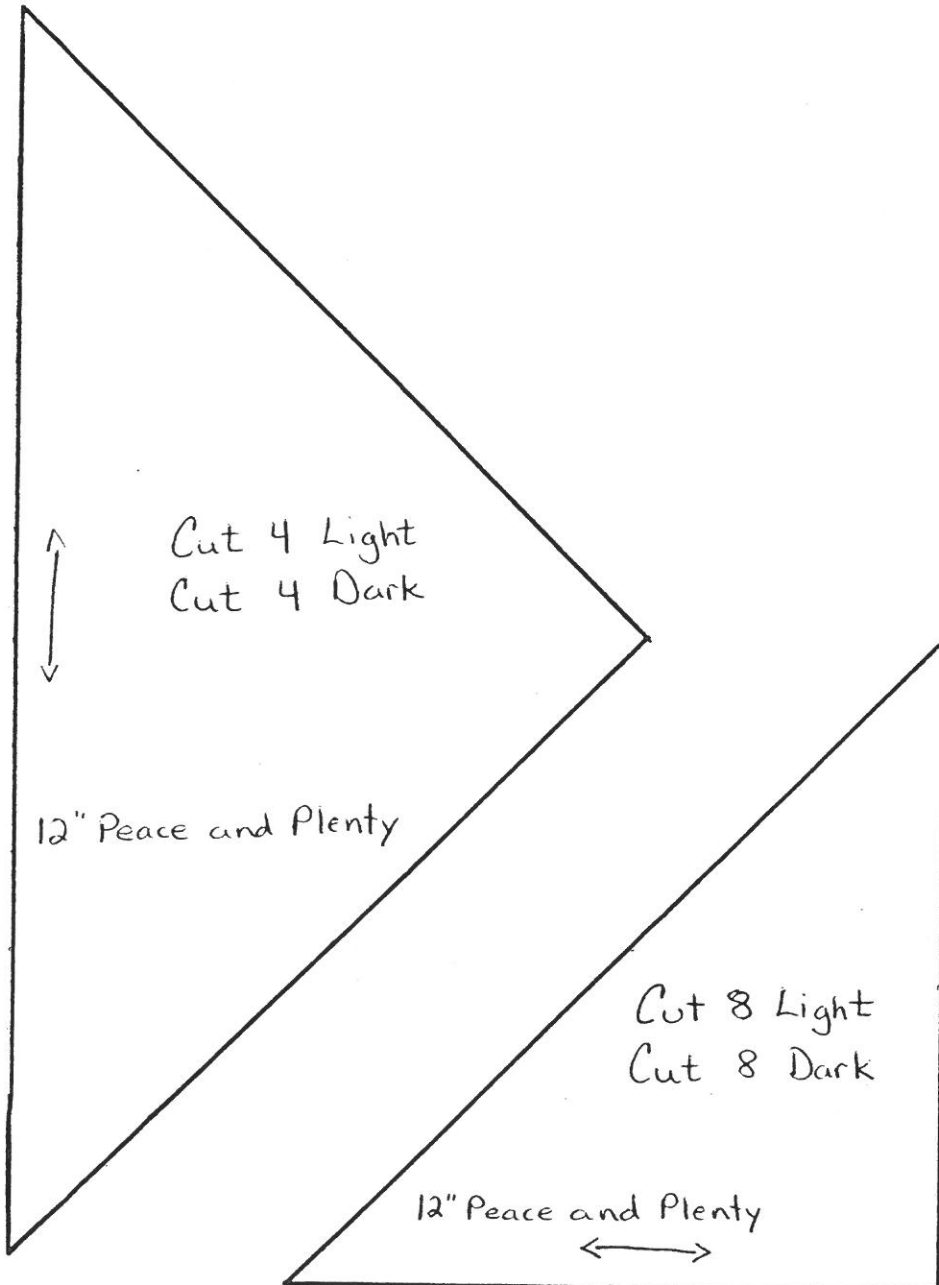

DECEMBER

"Christmas Wreath"

an original by
Fiona Bevis

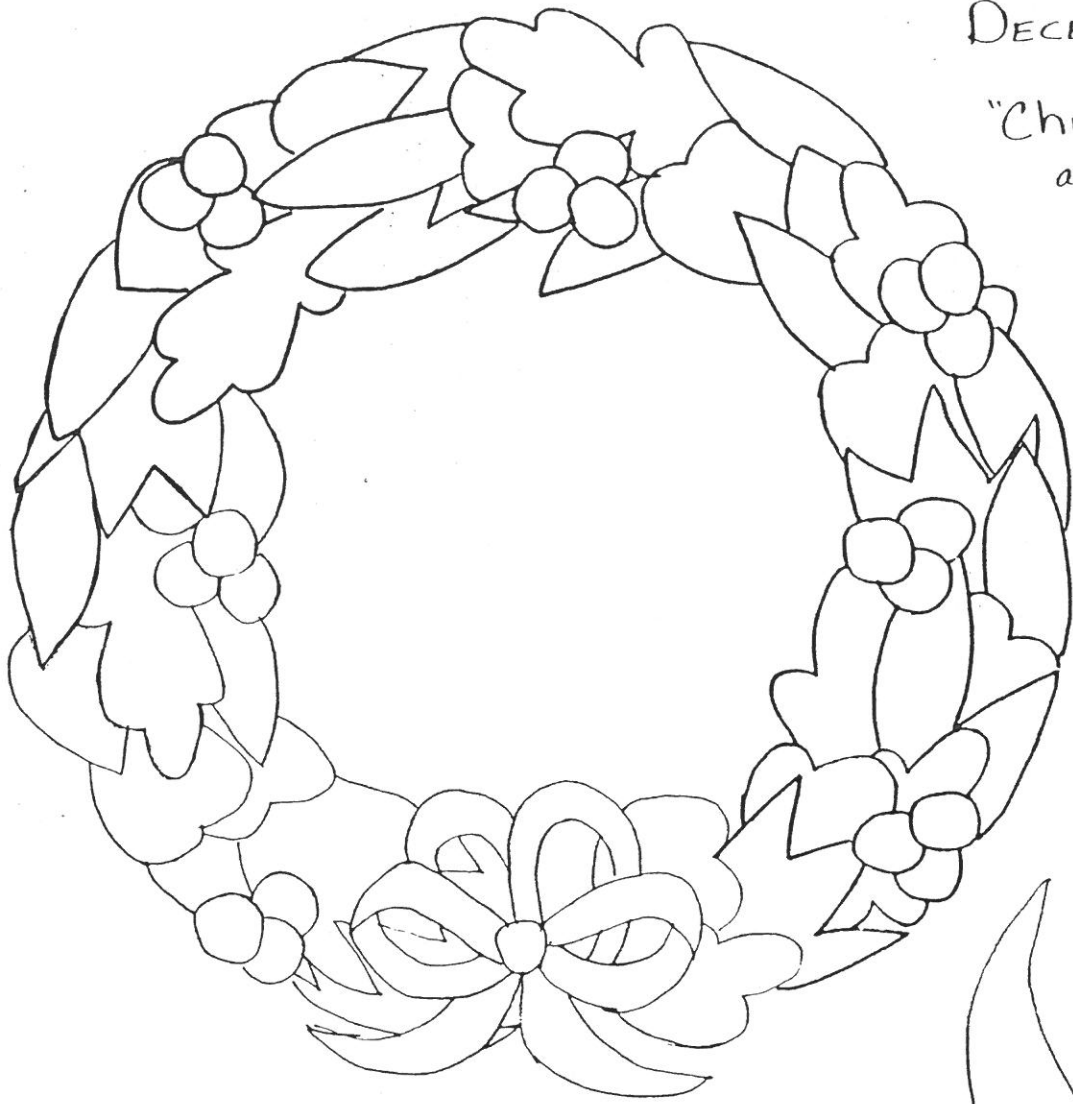

↔
Cut 1 Light
Cut 1 Dark

JANUARY NORTH WIND

-12" pieced quilt block
-Add 1/4" seam allowance

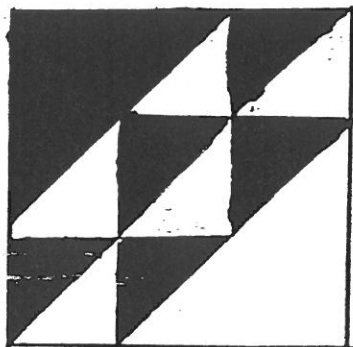
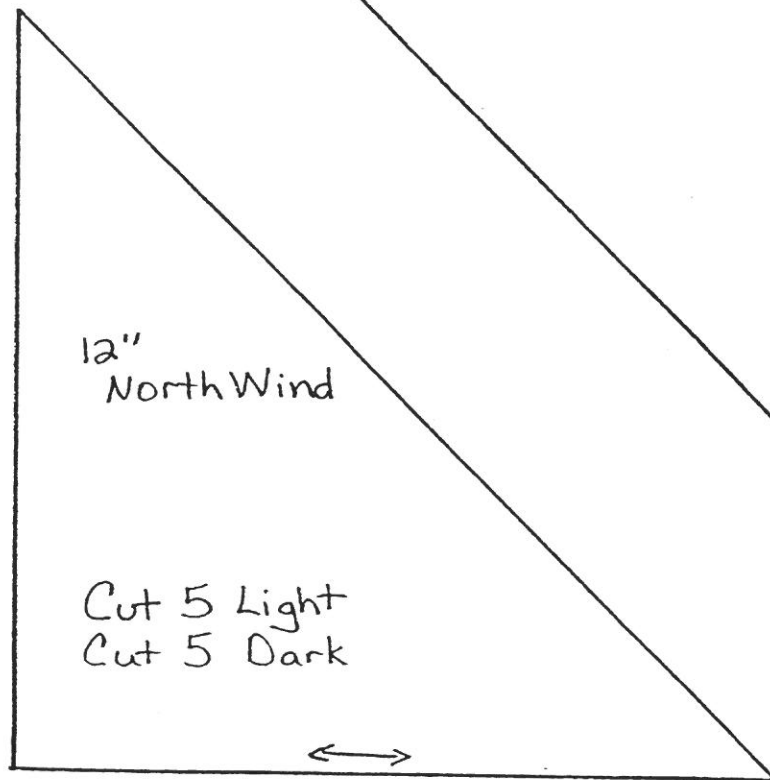

FEBRUARY "LOVE BIRDS"

- 12" applique quilt block
- Trace & cut the shapes
- Using freezer paper or any other method, applique the design to a 12 1/2" block

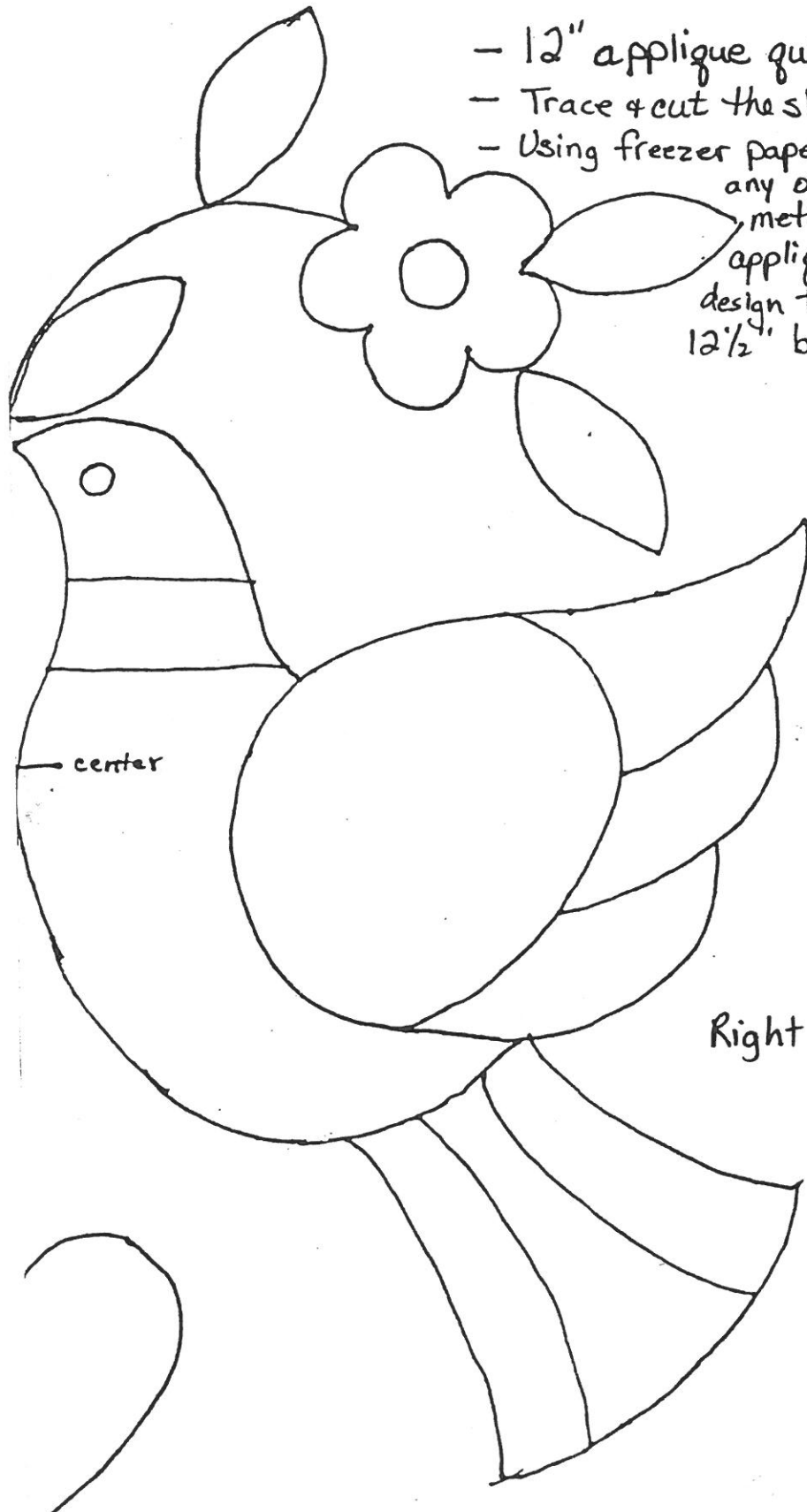

center

Right side



February
"Love Birds"

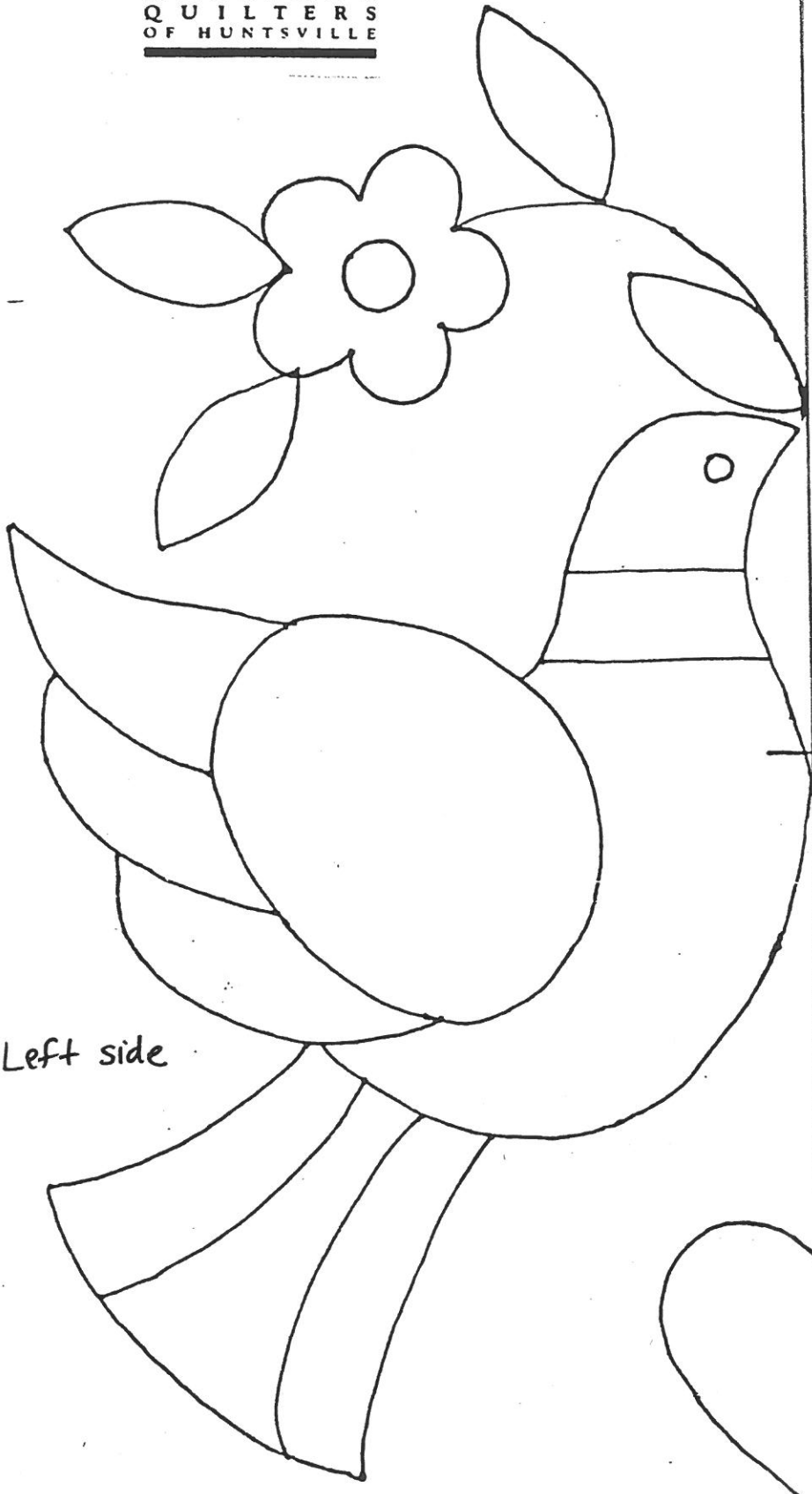

Left side

MARCH

"Windblown Square"

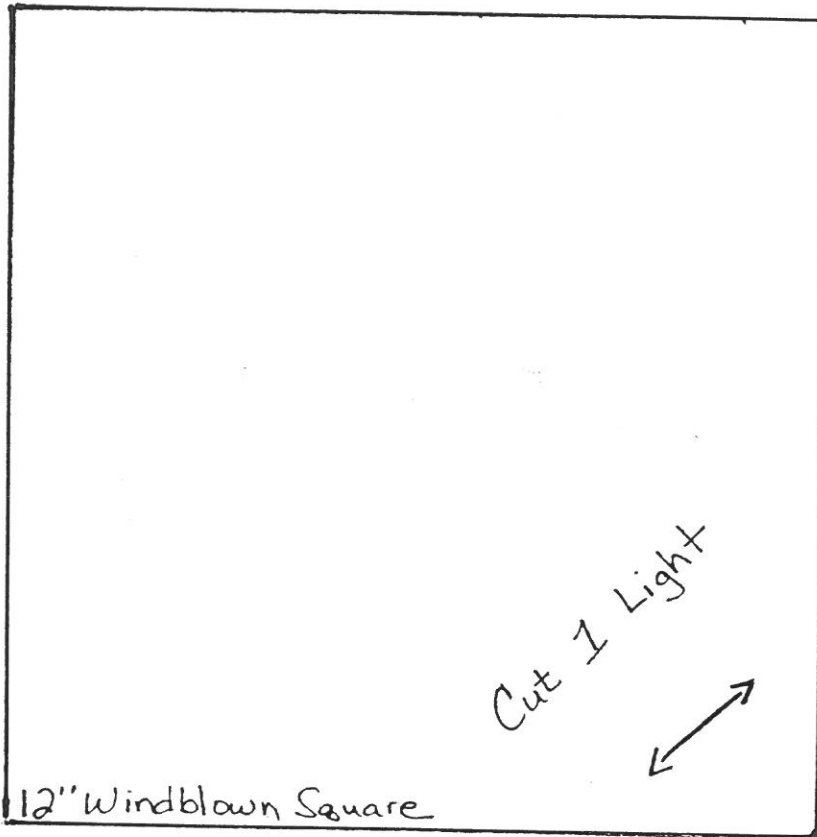

- 12" pieced quilt block
- Add 1/4" seam allowance

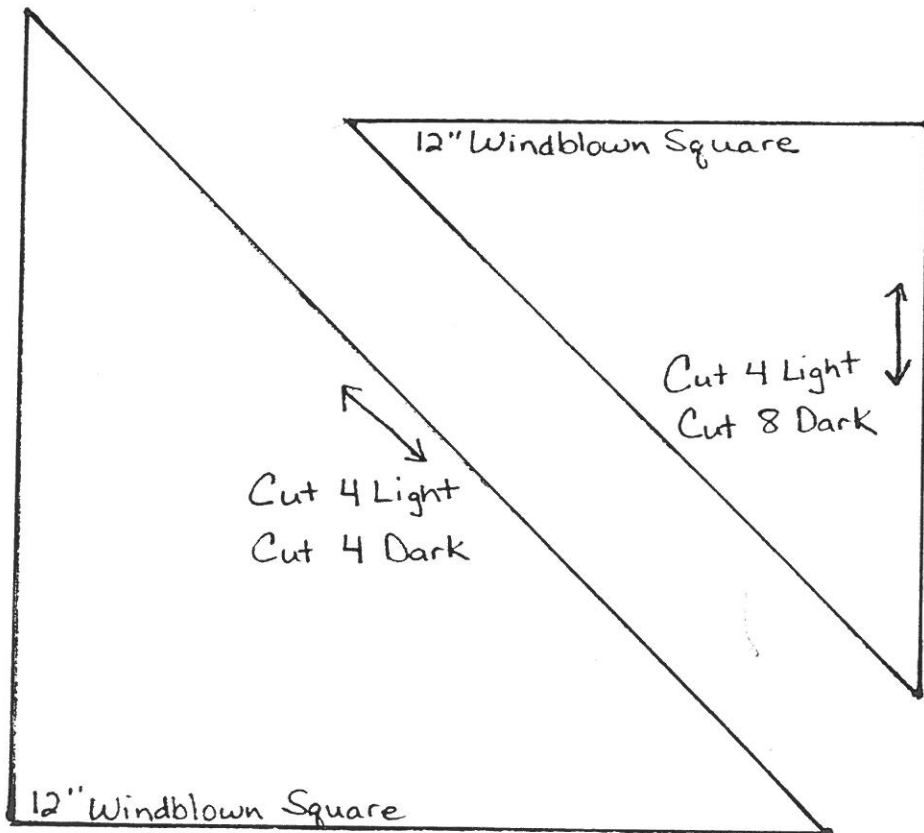
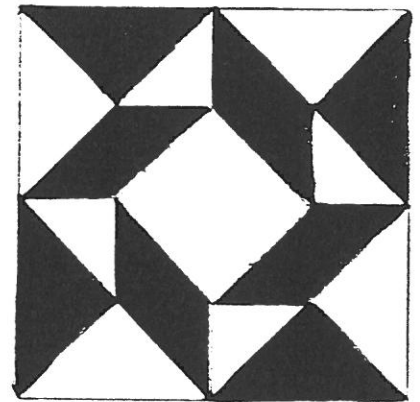

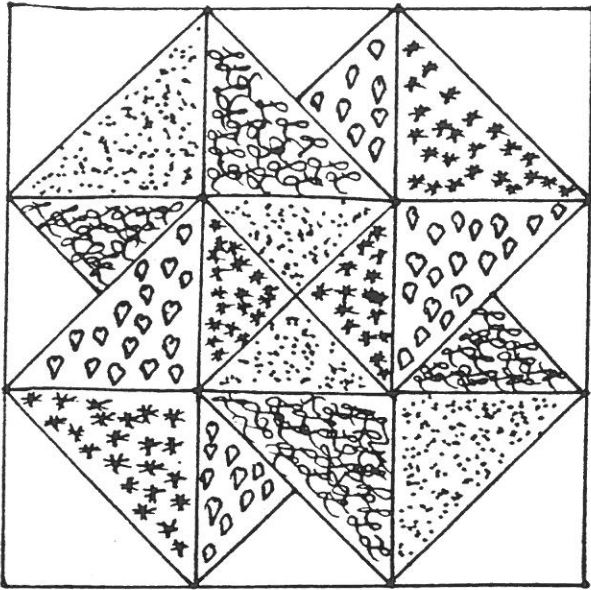

APRIL "Card Trick"

- 12" pieced block
- add 1/4" seam allowance.

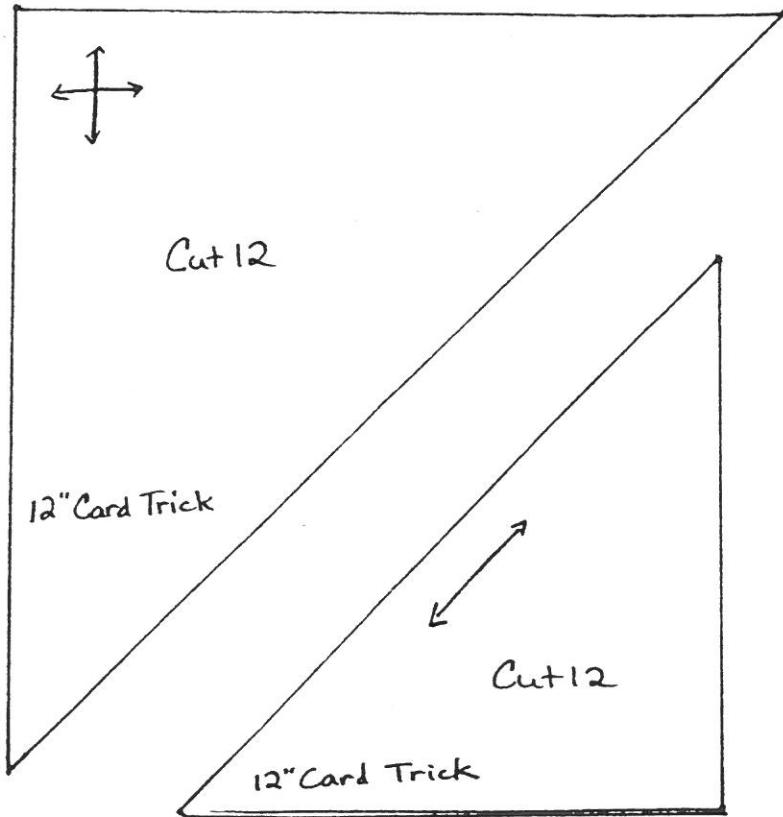

MAY

"May Basket"

= 12 inch pieced
and appliqued
block

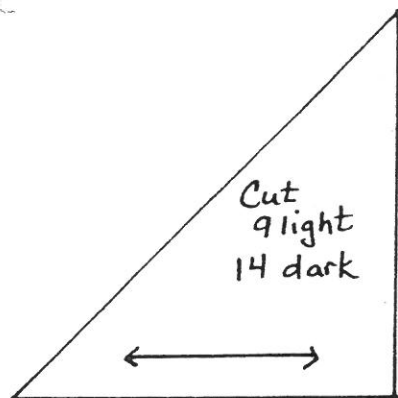
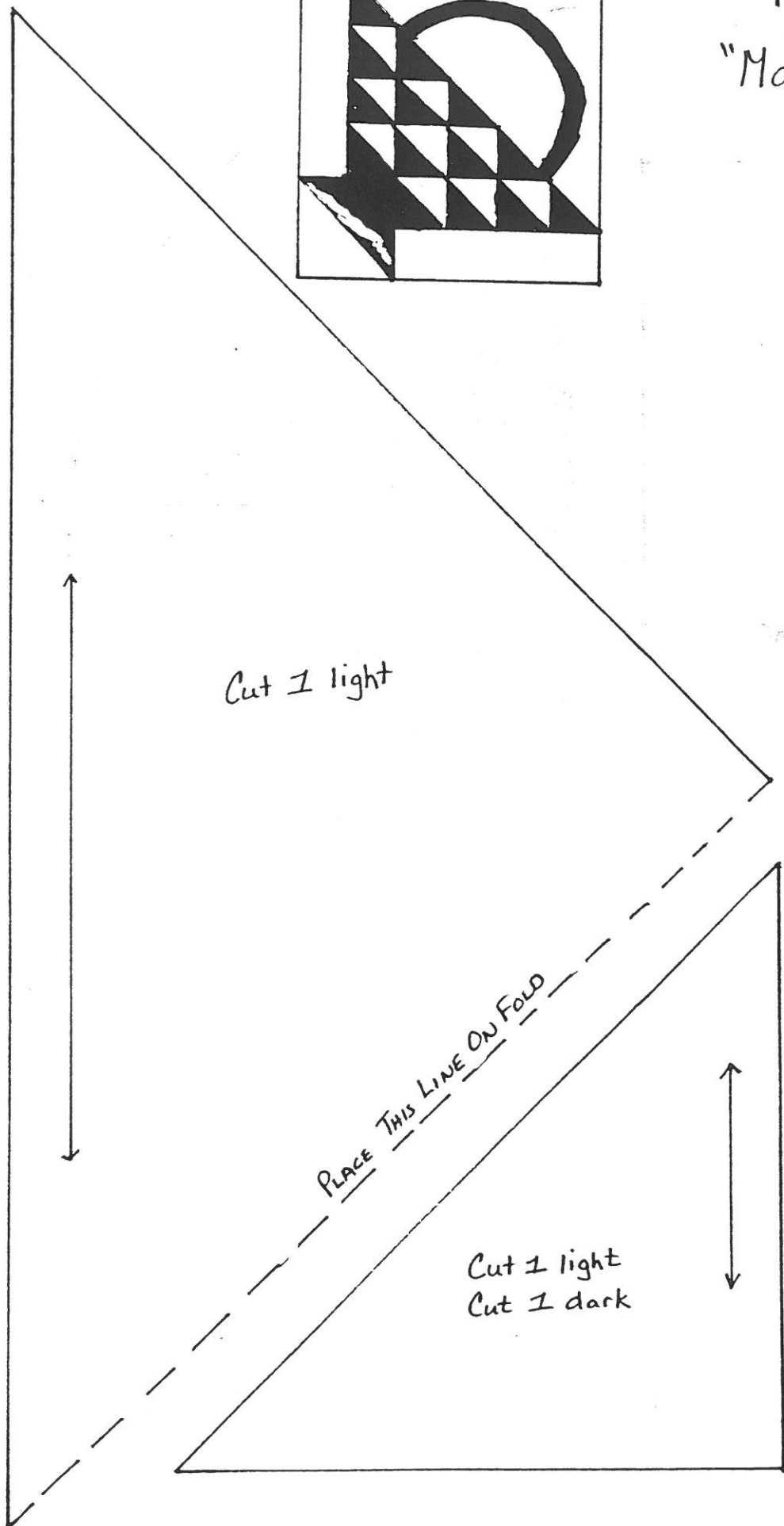
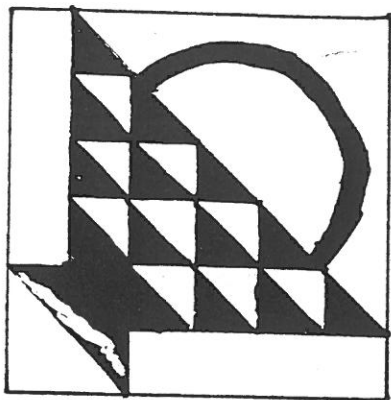

JUNE

"Rose Wreath"

from the collection
of the Boulder
Colorado Historical
Society.

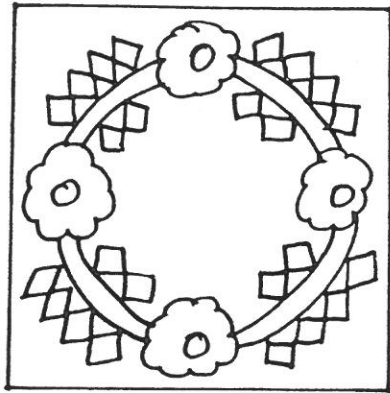

- 12" applique block
- add 1/4" seam allowance

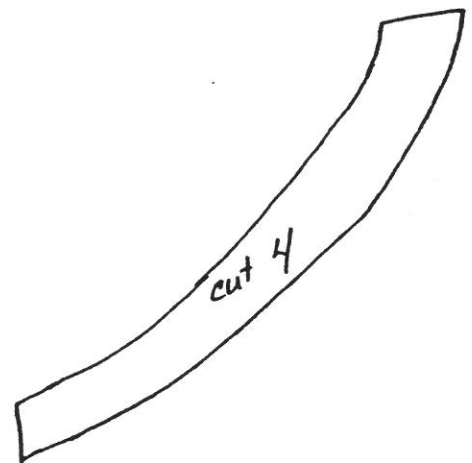
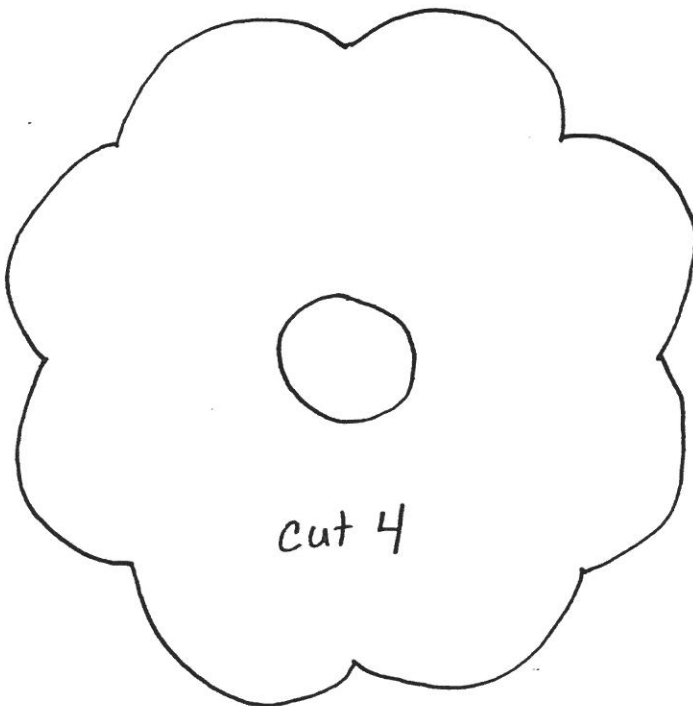

JULY

"Monkey Wrench"

- 12" pieced block

- Add 1/4" seam allowance

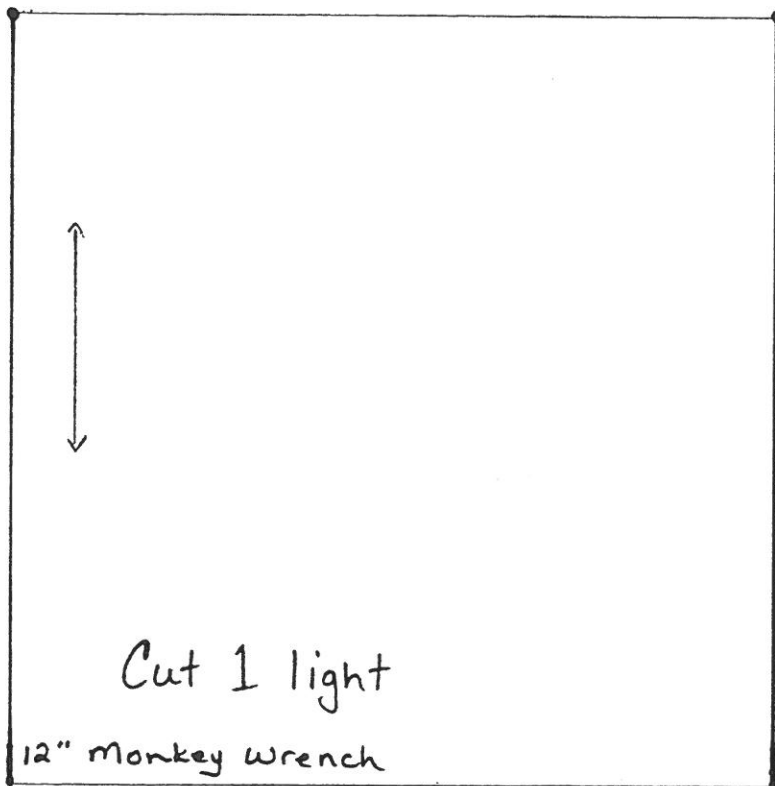
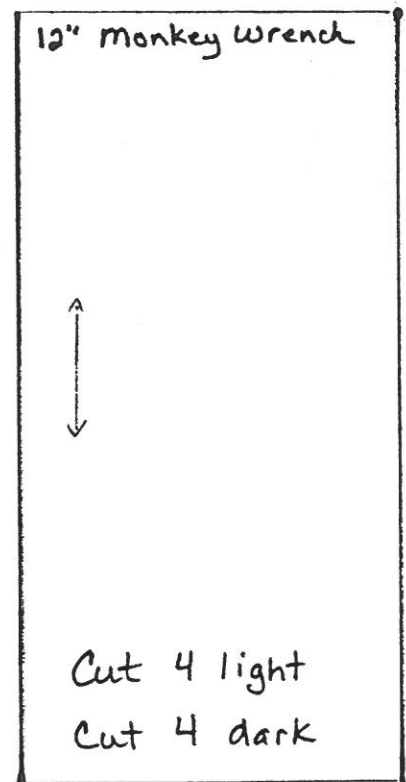
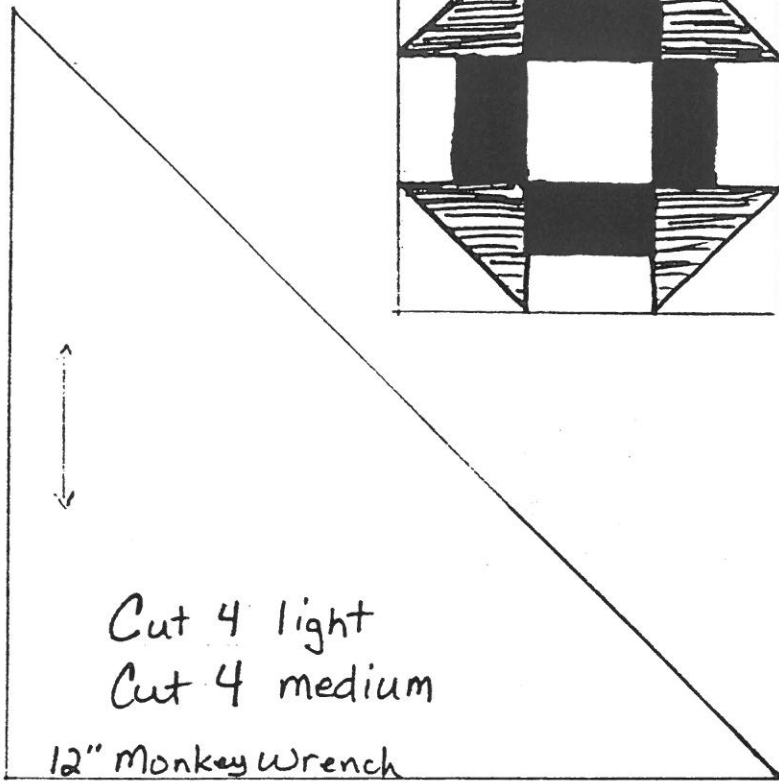
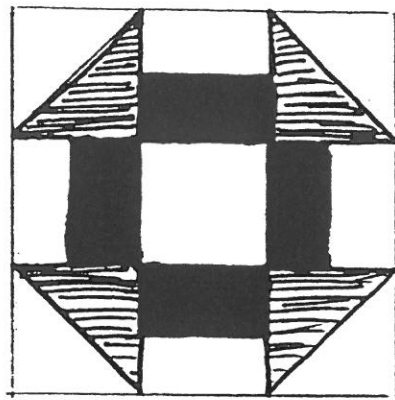

AUGUST

"Toad in a Puddle"

-12" pieced block

-Add 1/4" seam allowance

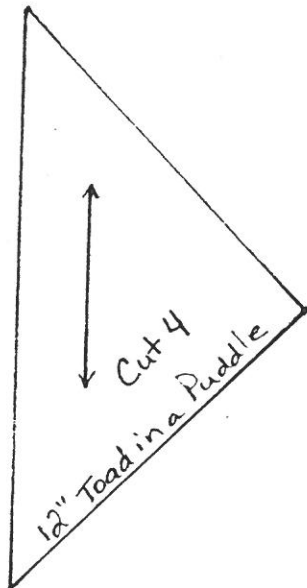
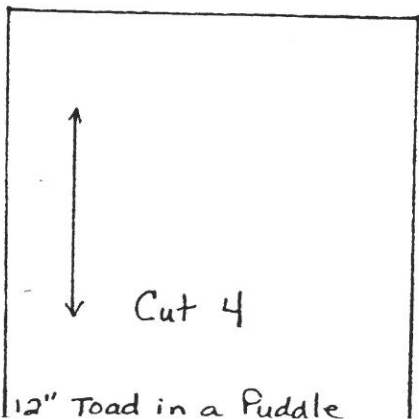
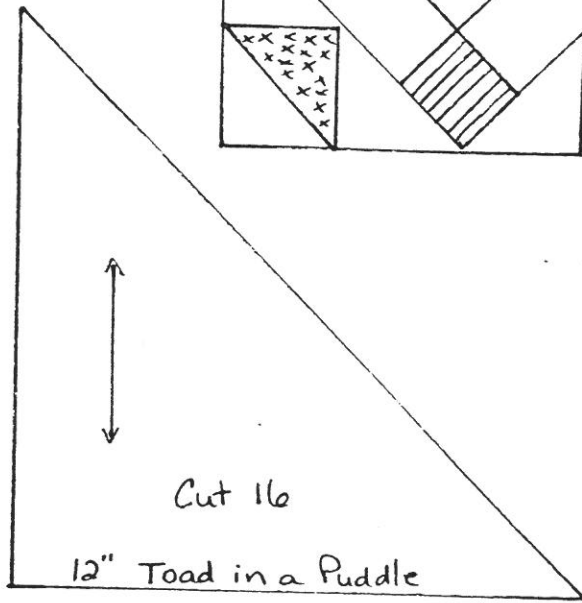
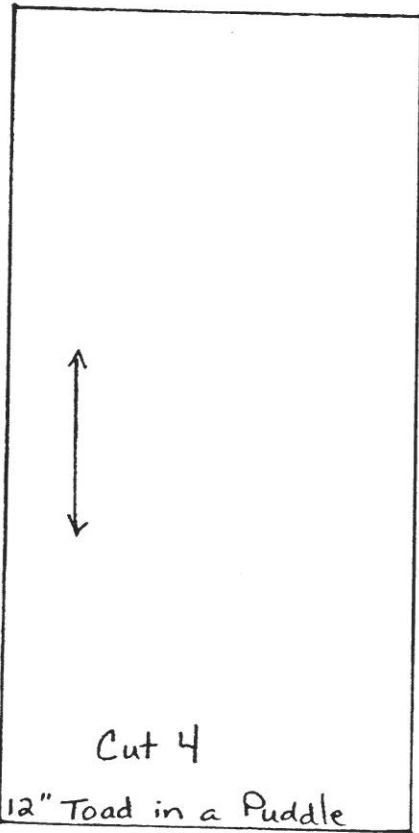
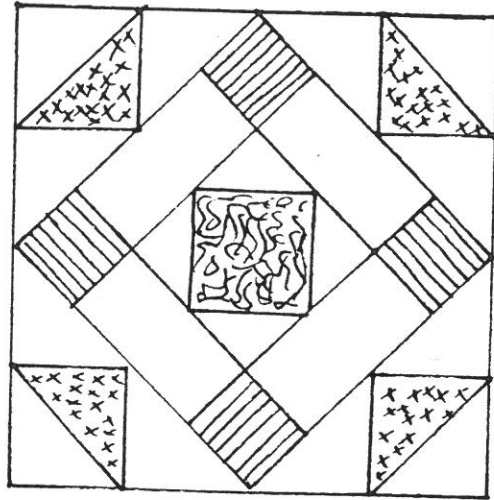
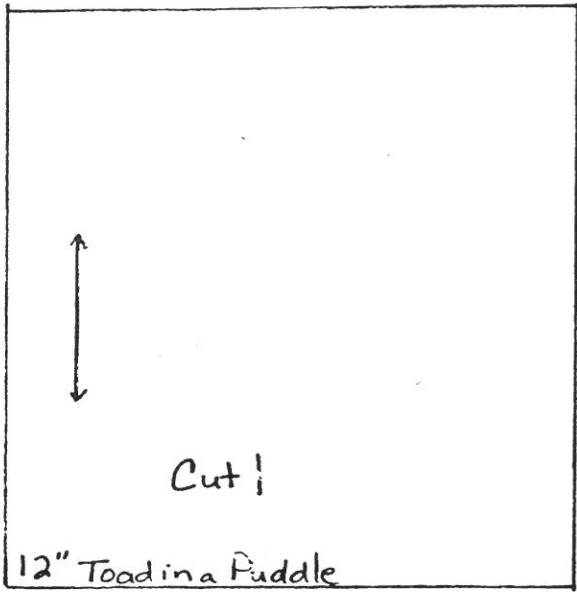

Heritage Quilters of Huntsville

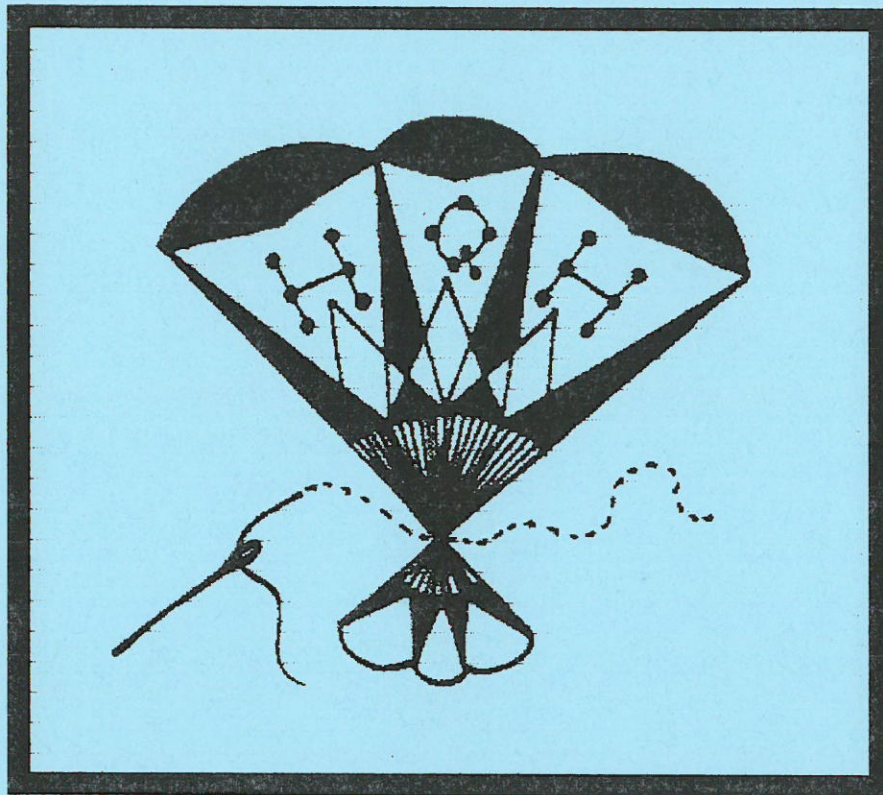

Block of the Month Patterns

1989/1990

**Baltimore Album style 16" blocks
September 1989 thru August 1990
designed by Kim Hamby**

September 1989
Block of the Month

1

16" finished
block

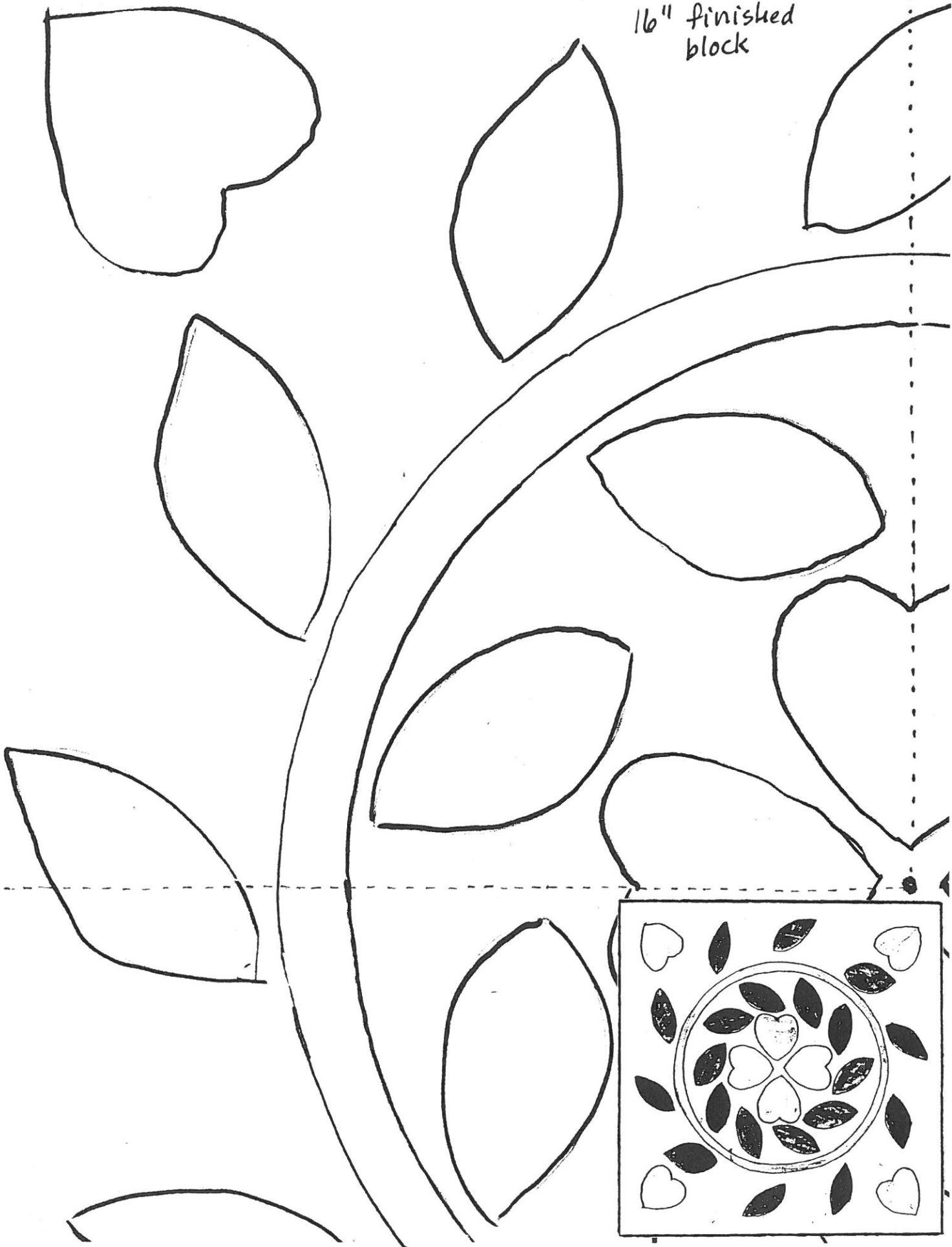

October 1989
Block of the Month
16" finished block

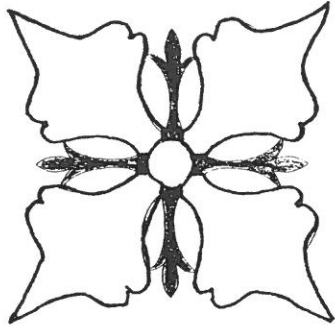

Adapted from an 1830's
Baltimore Album quilt

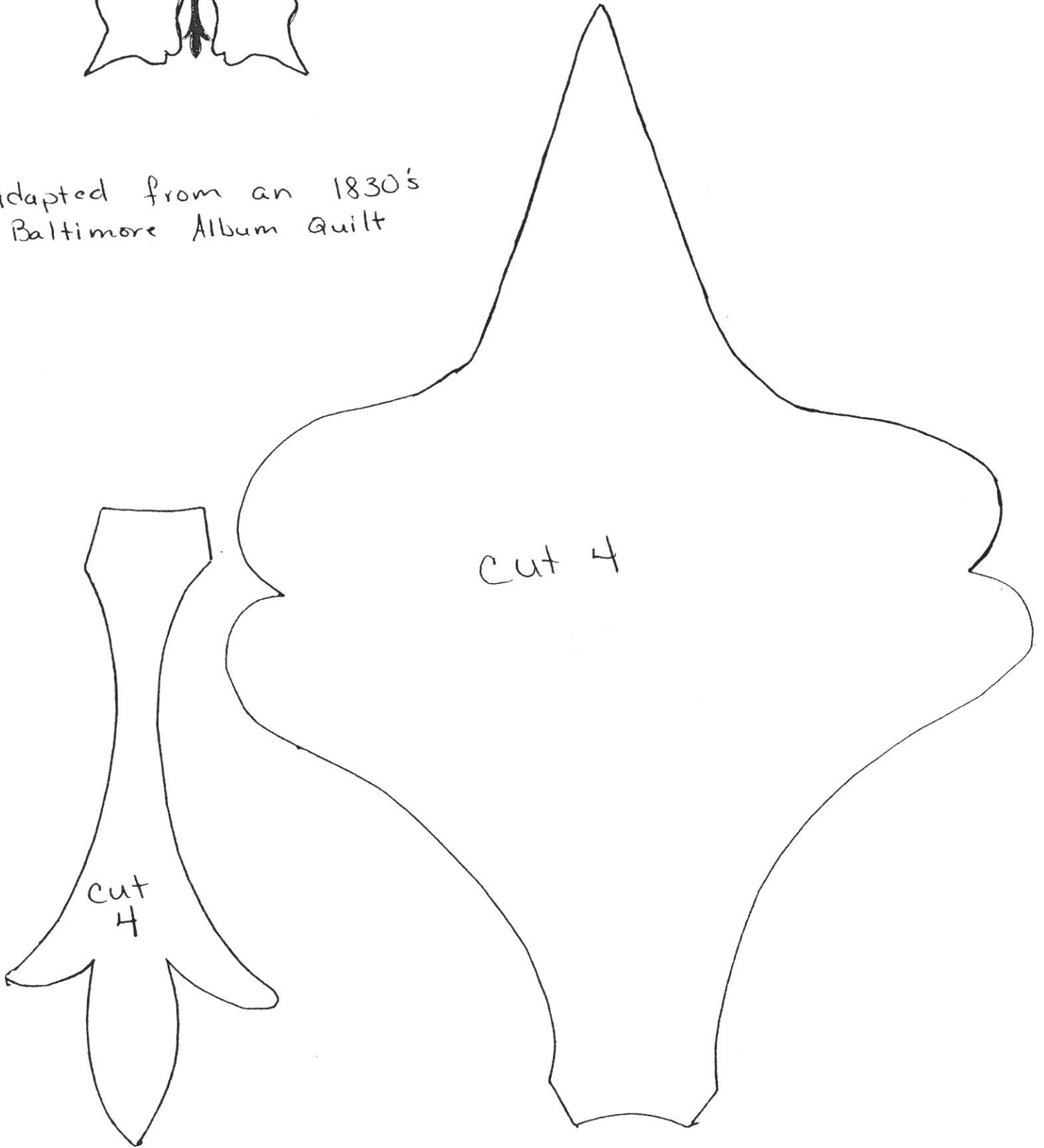

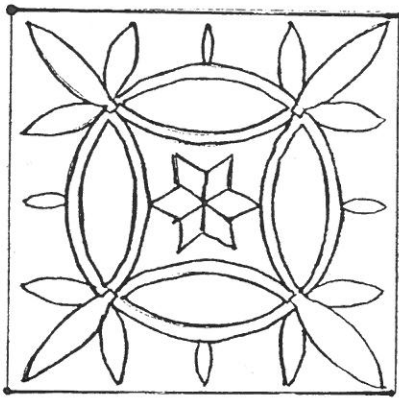

November 1989
Block of the Month
16" finished

Adapted from c1845
quilt possibly from
Pennsylvania

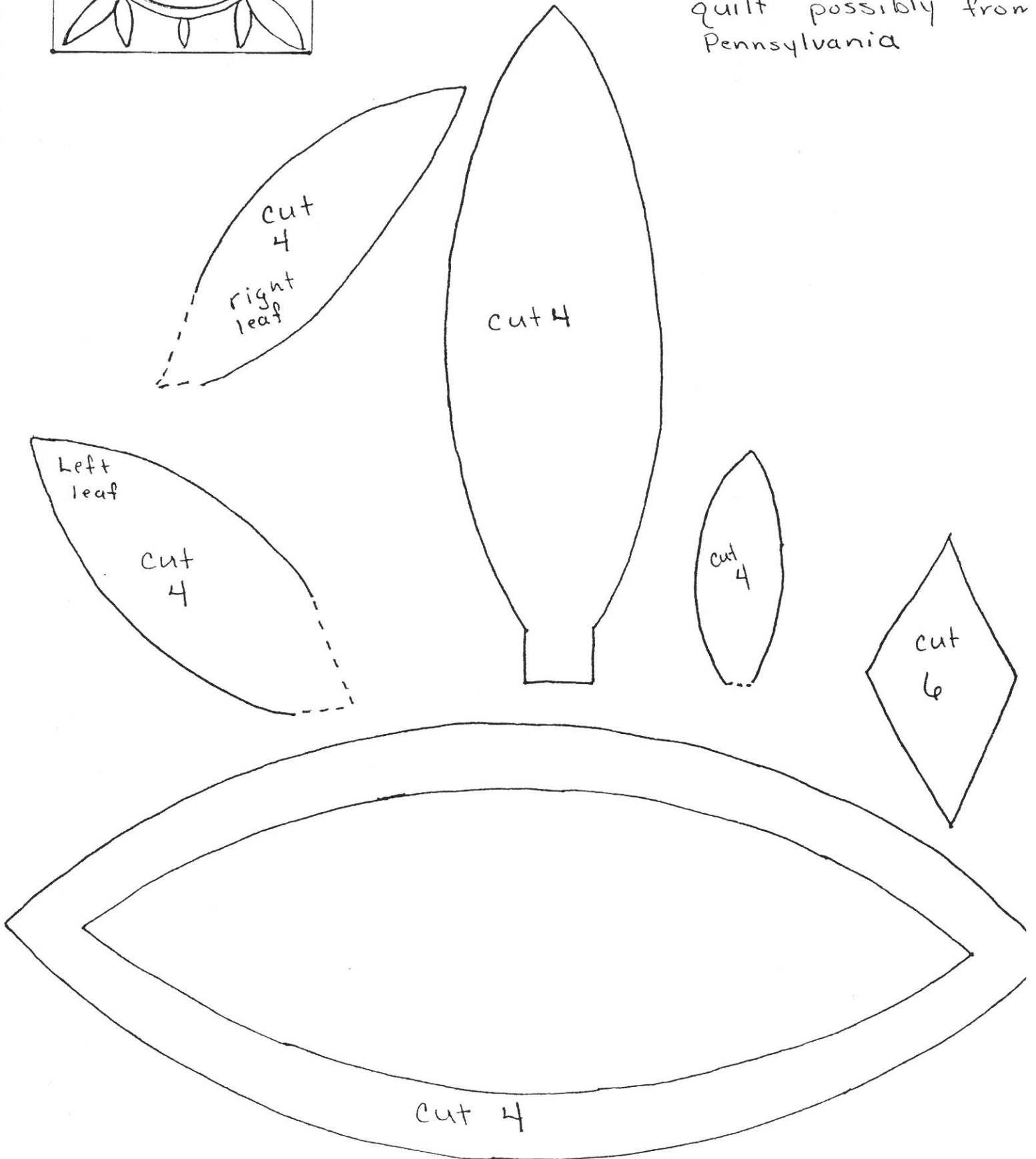

Nov. 1989 3

Alternate
with hearts

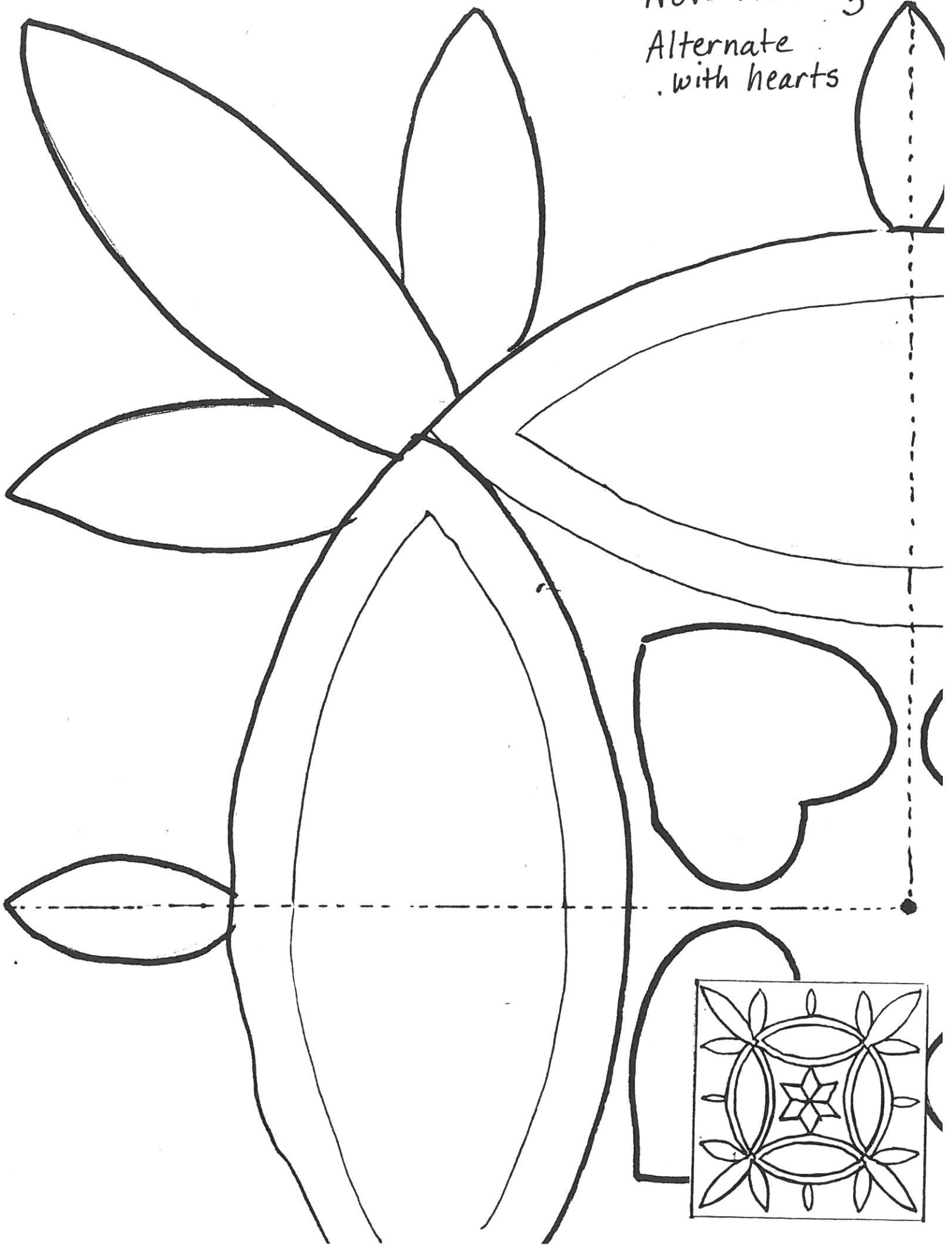

December 1989
Block of the Month
16" finished Block

Adapted from a quilt
pictured in A Treasury
of American Quilts

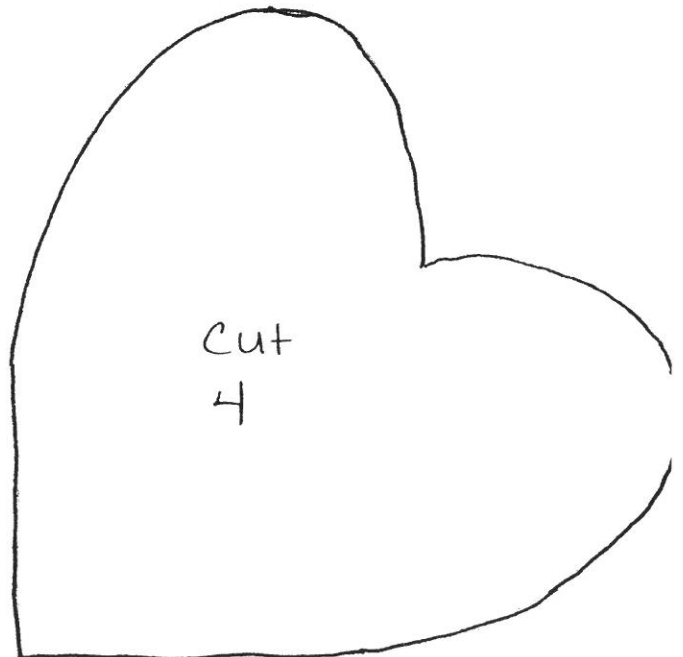
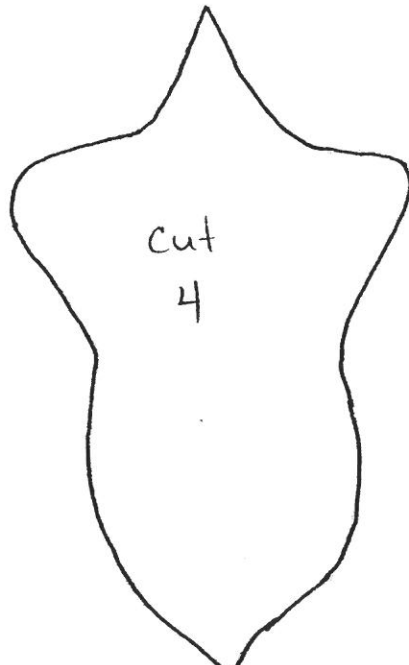
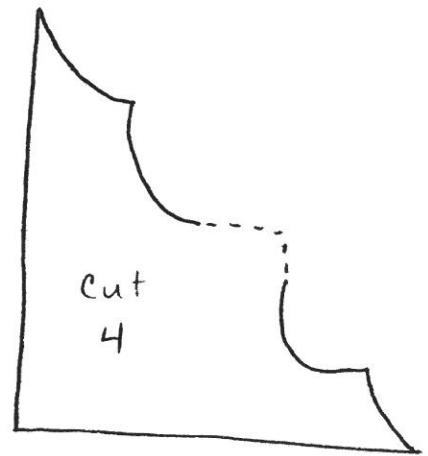
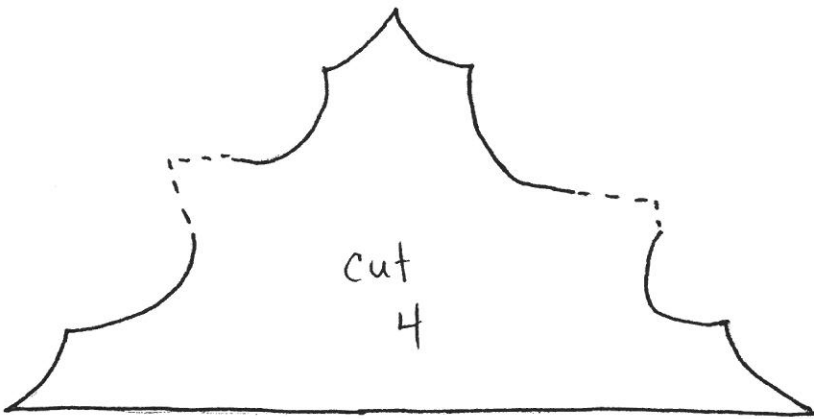
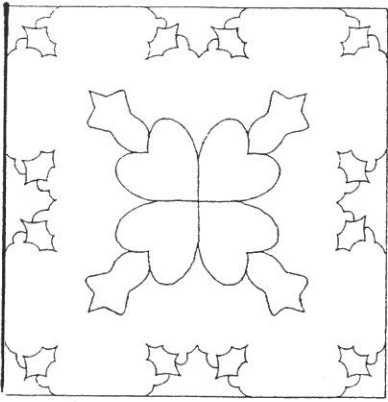

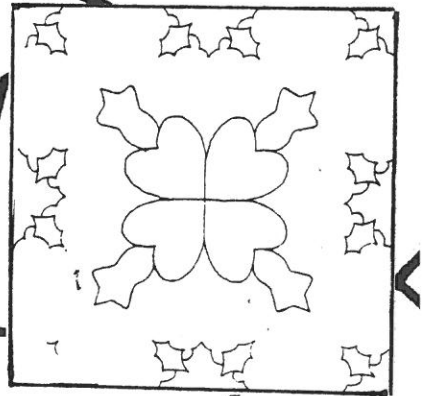
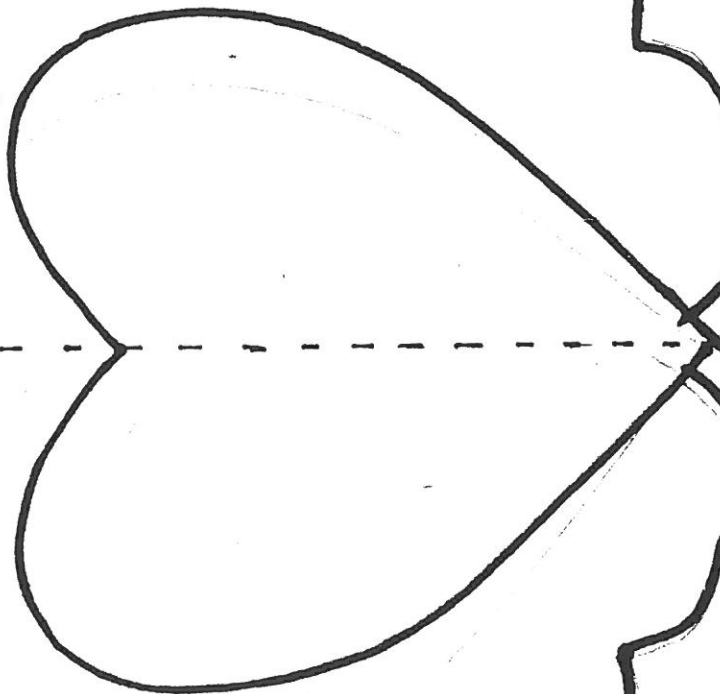
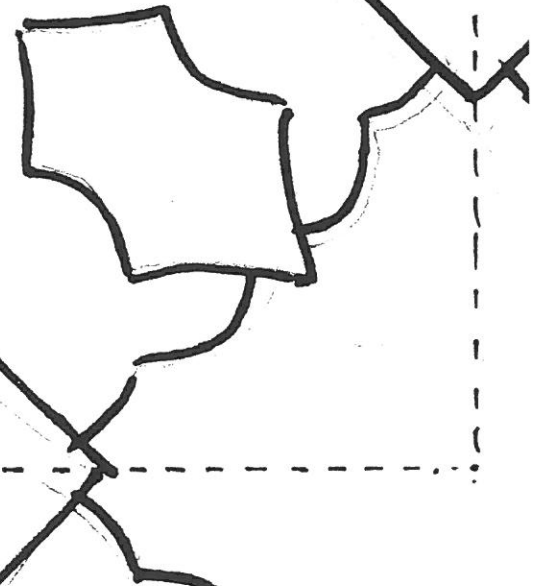
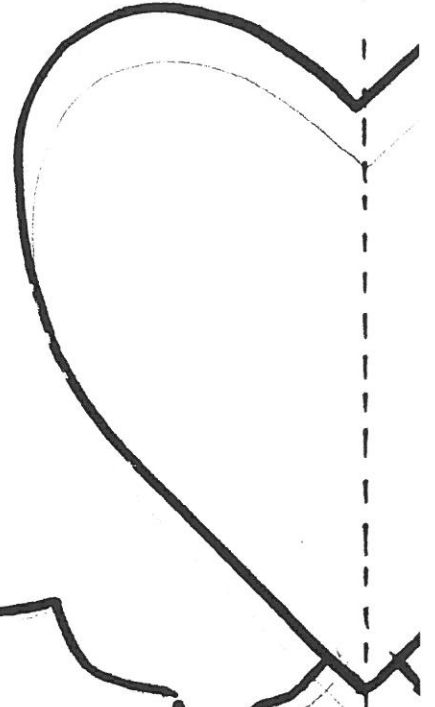
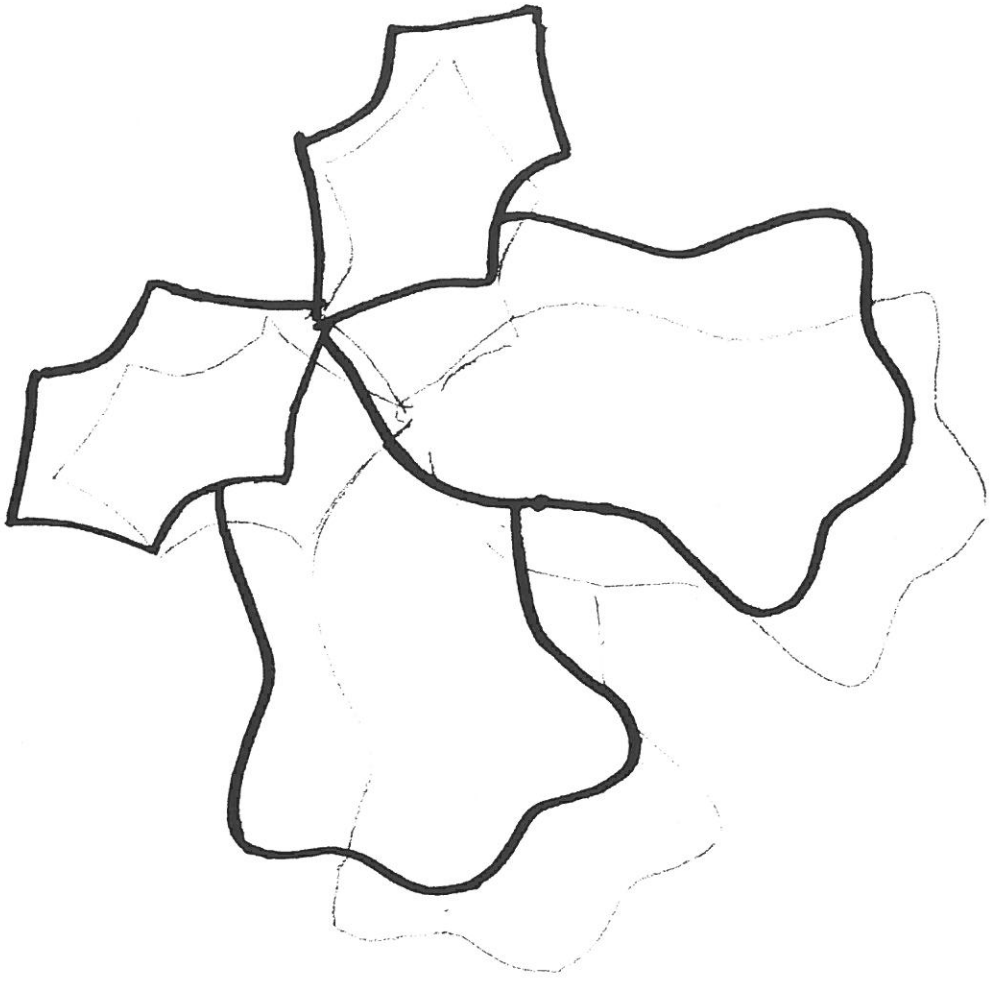

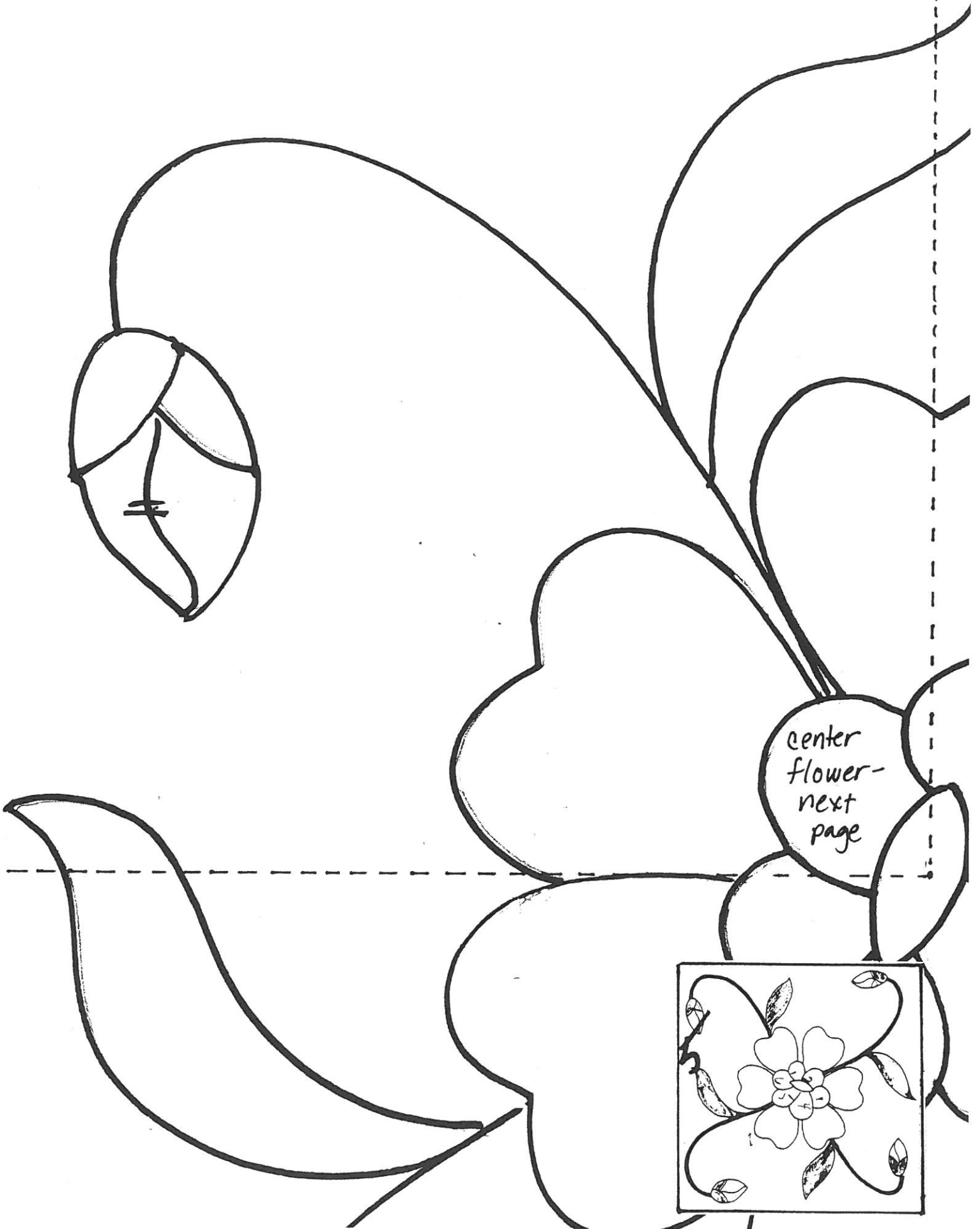

center
flower -
next
page

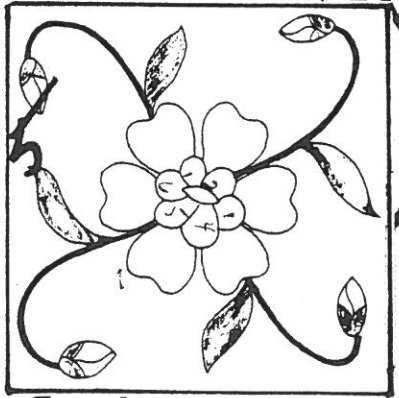

Block 5
center
flower

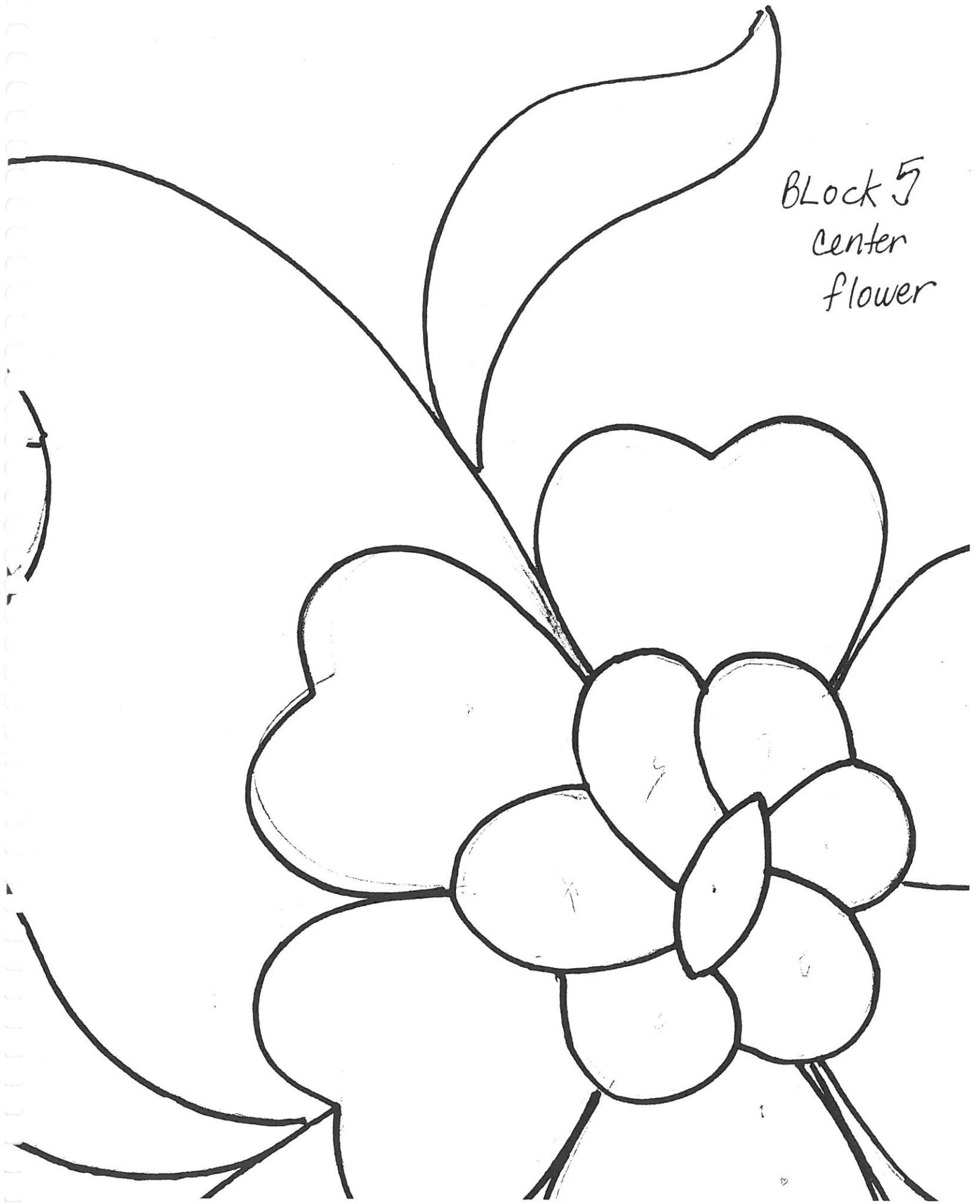

February 1990
Block of the Month
16" finished block

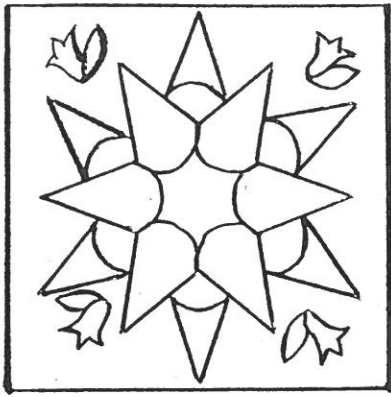

Adapted from
Treasury of American
Quilts p.5
c 1845, possibly
Pennsylvania

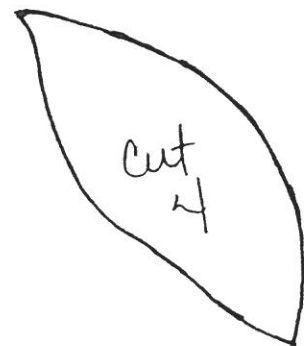
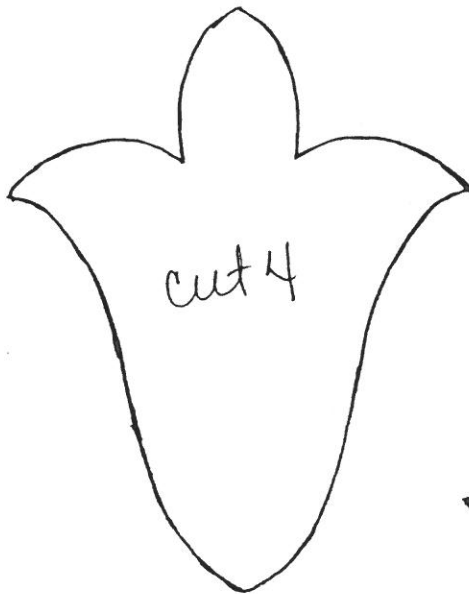
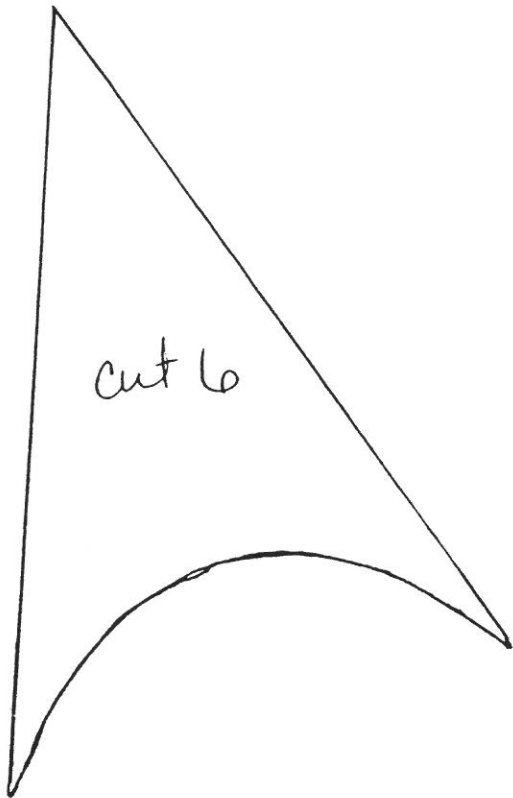
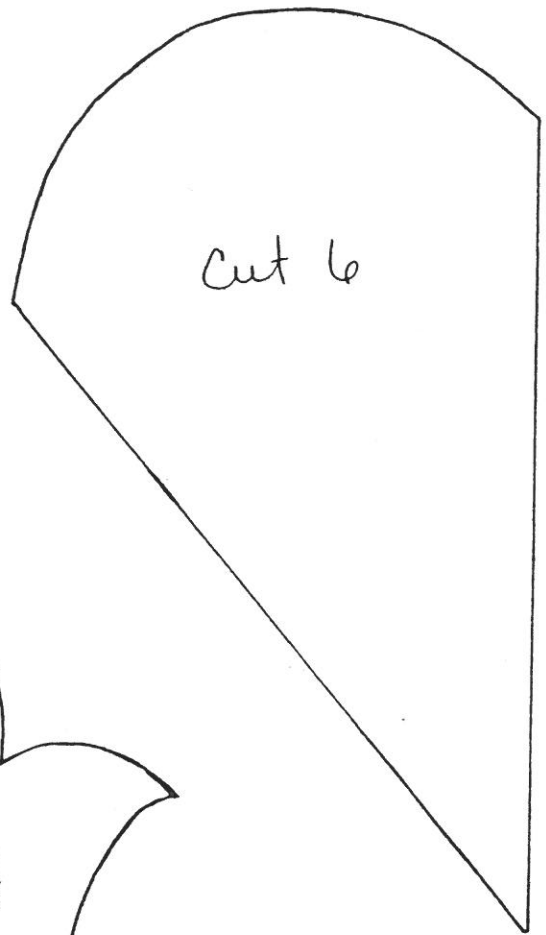

26

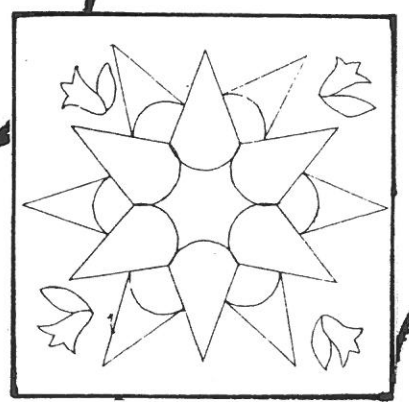
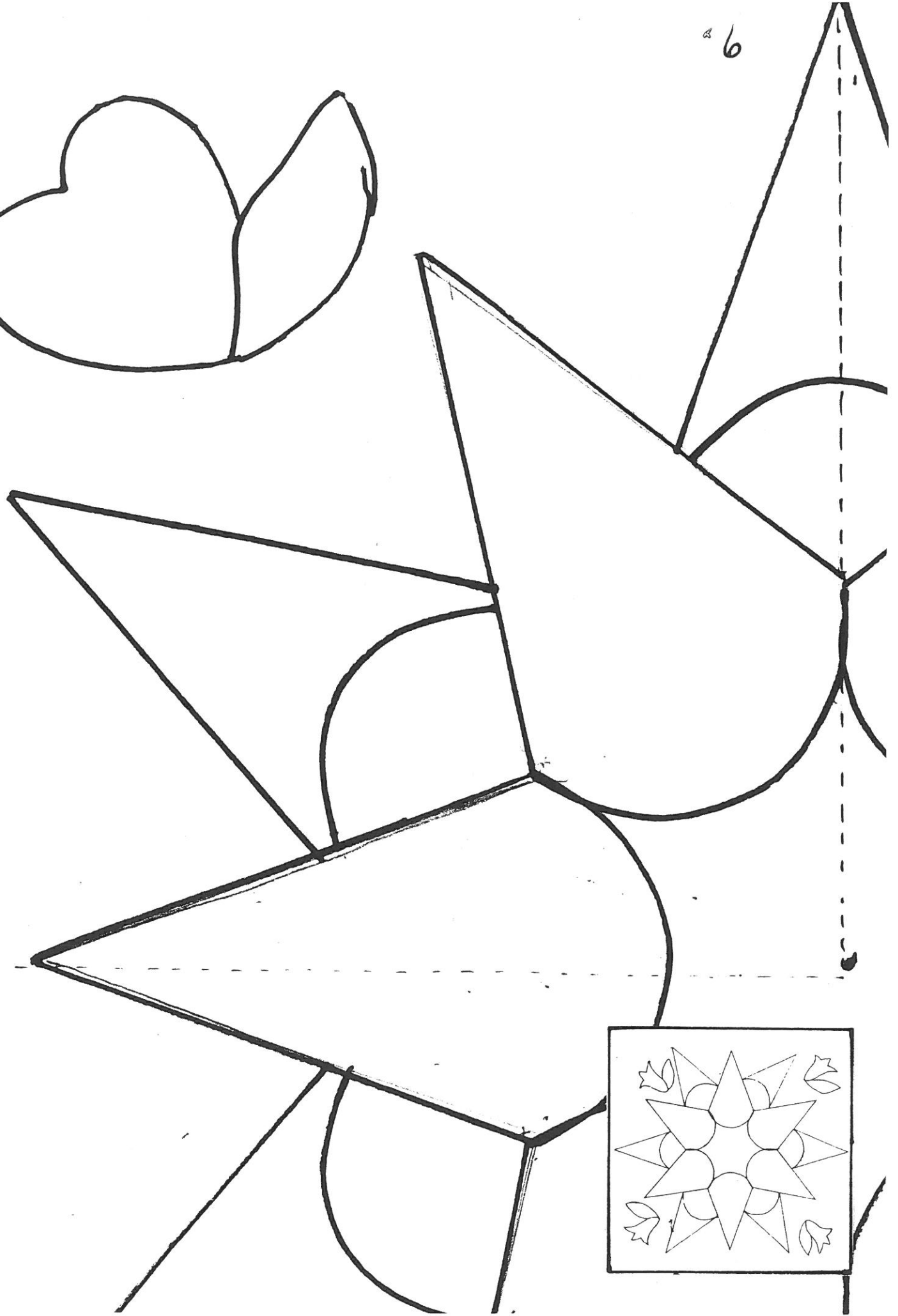
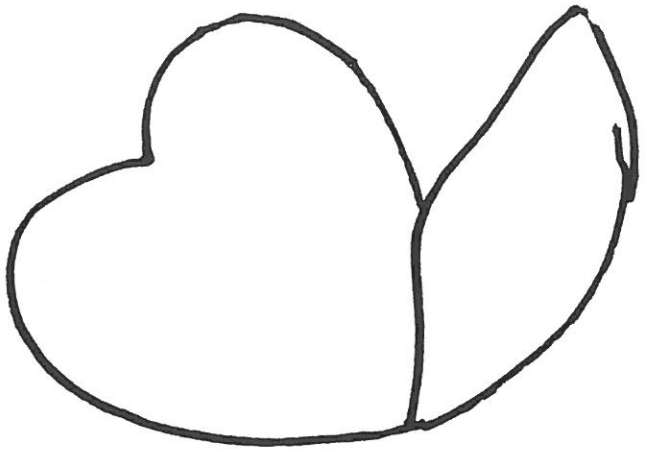

March 1990

Block of the Month

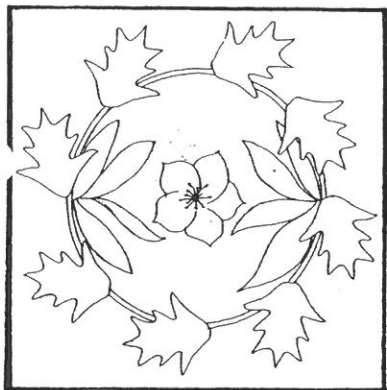

31 Quilting For Your Home

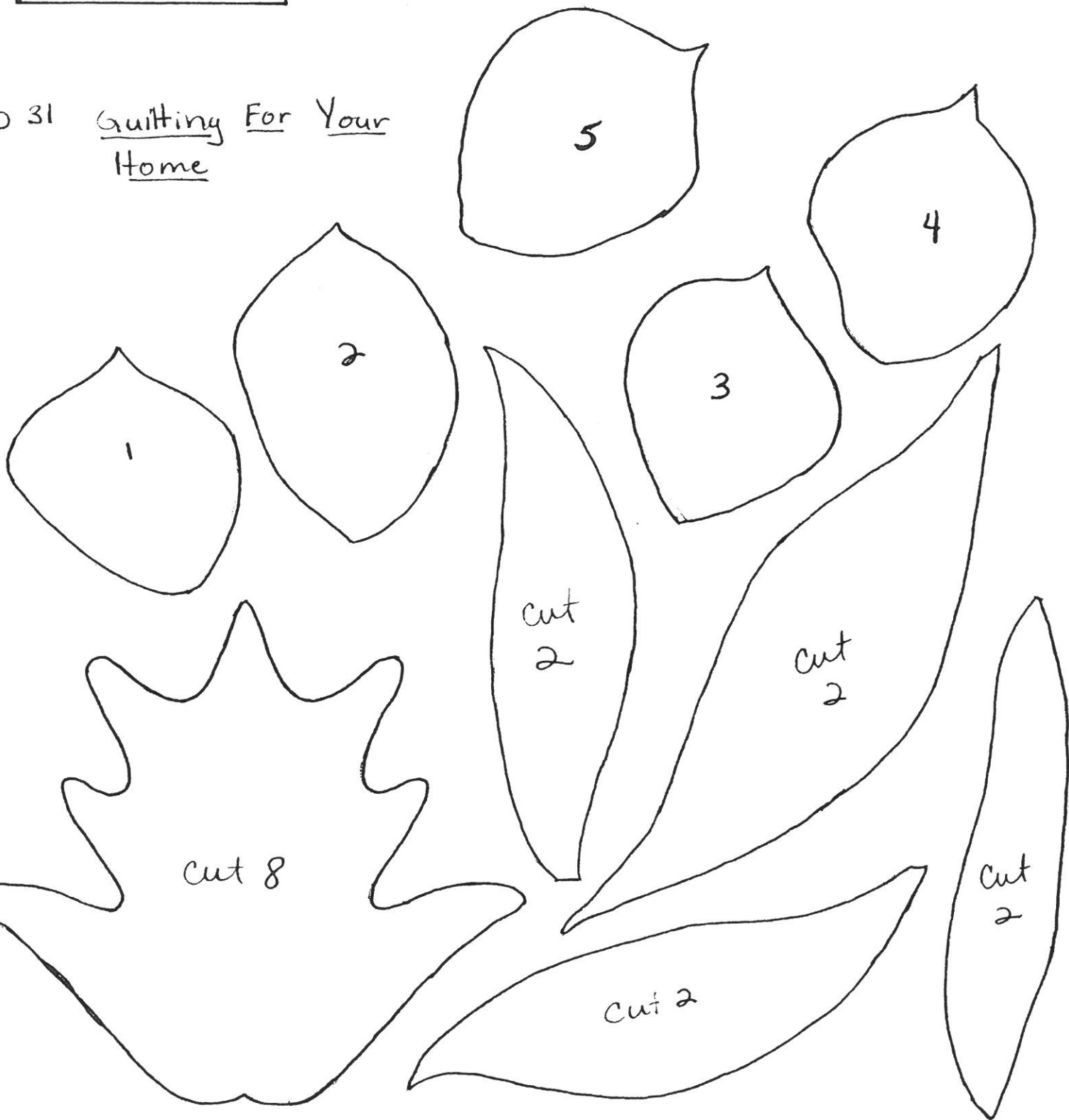

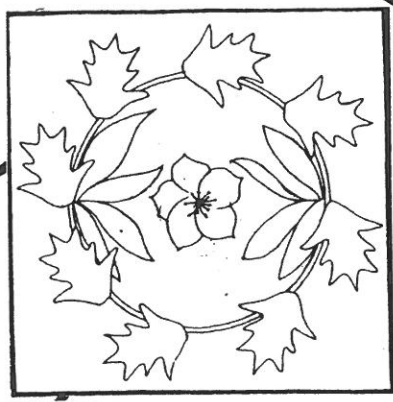
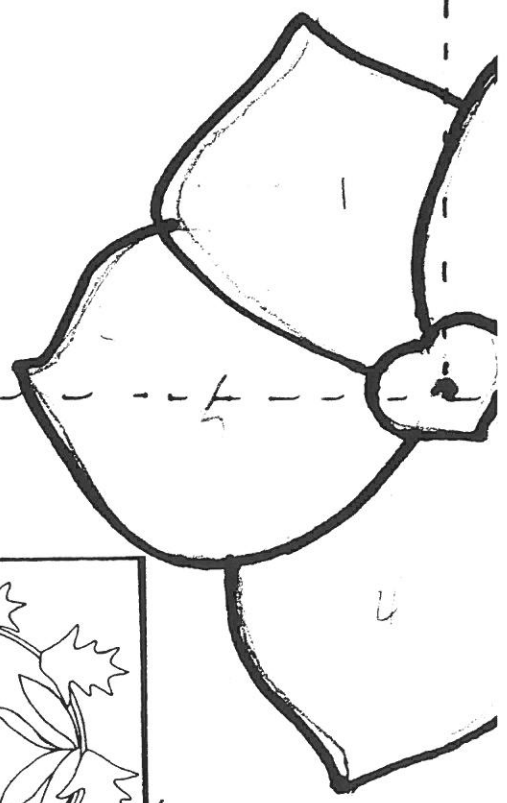
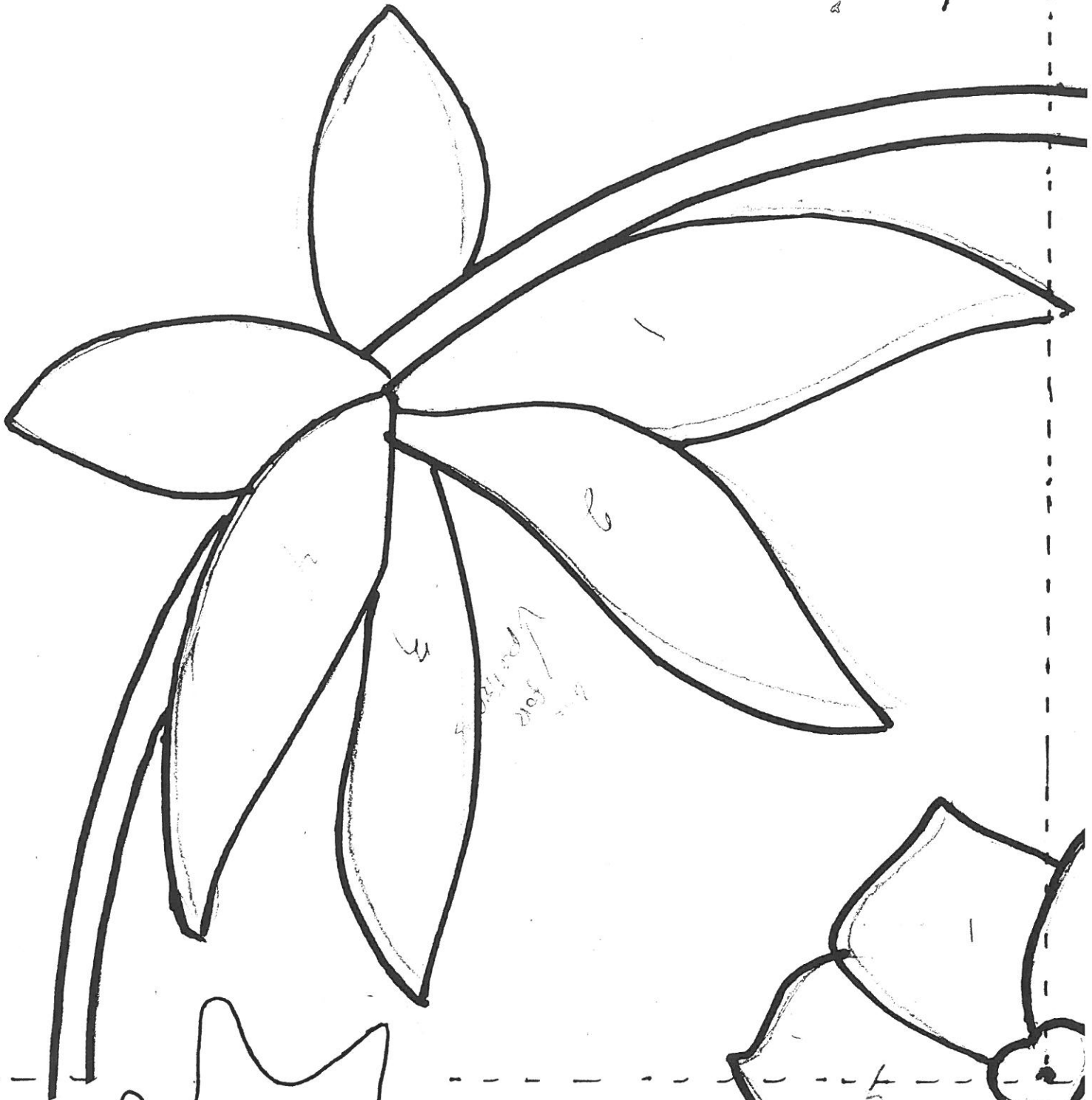

Block of the Month

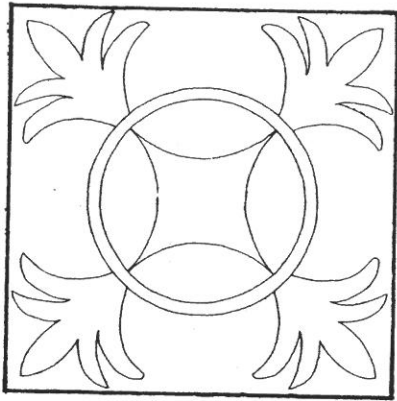

April 1990

p87 Quilting as
a Hobby

Circle diameter
inside $8\frac{3}{8}$ "
outside $9\frac{3}{8}$ "

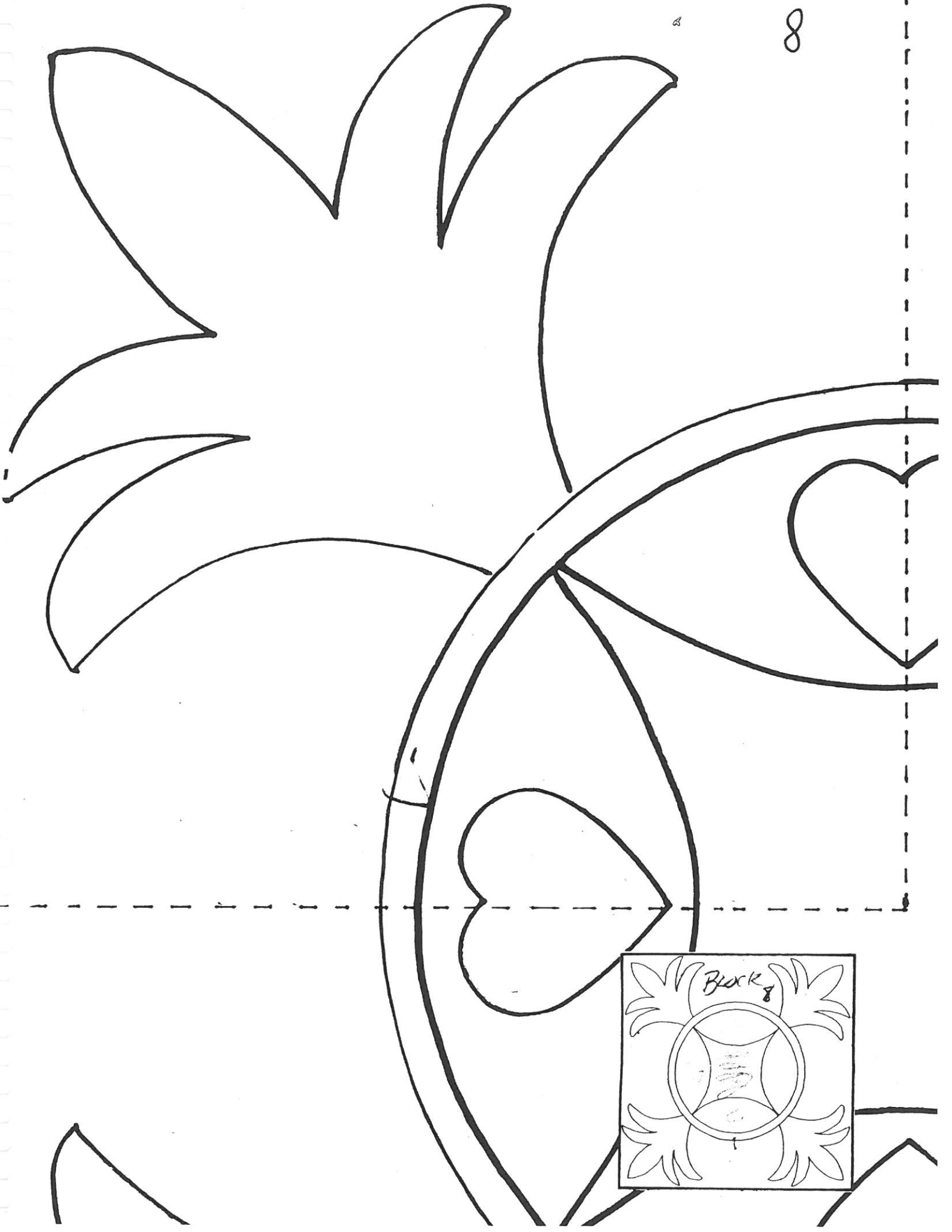

Block of the Month

May 1990

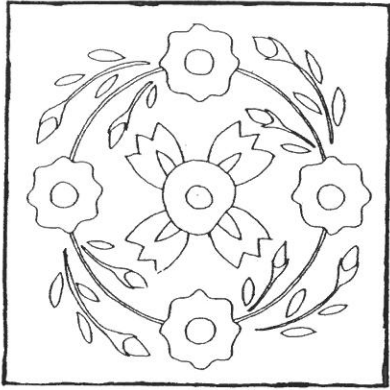

P. 99 The Stenciled
Quilt "Rose Bud
& Wreath"

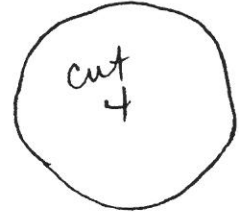
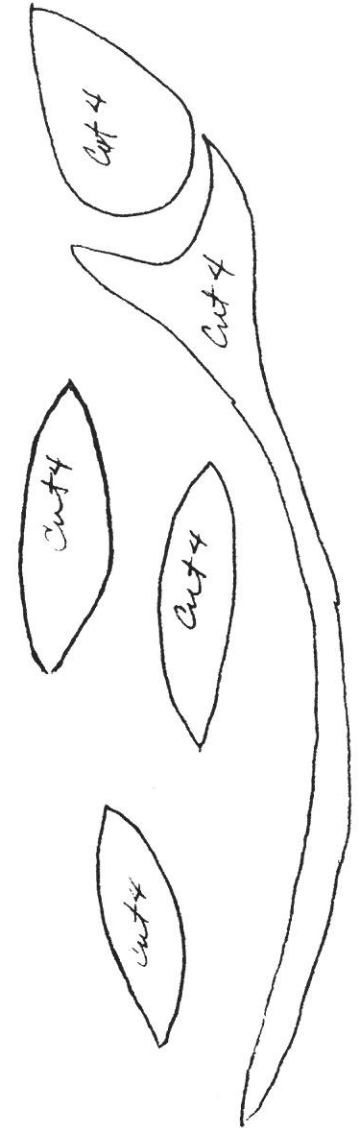
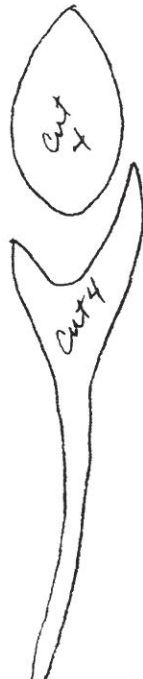
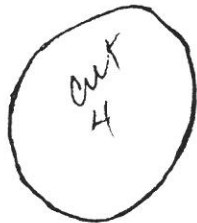
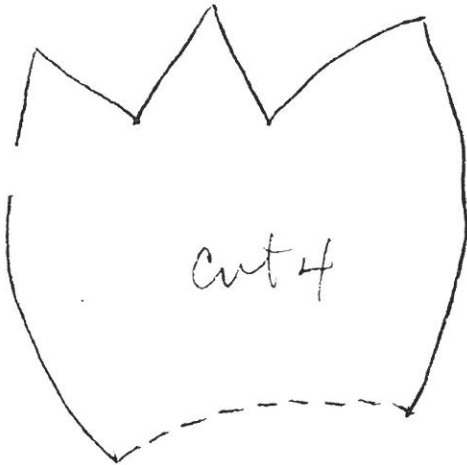

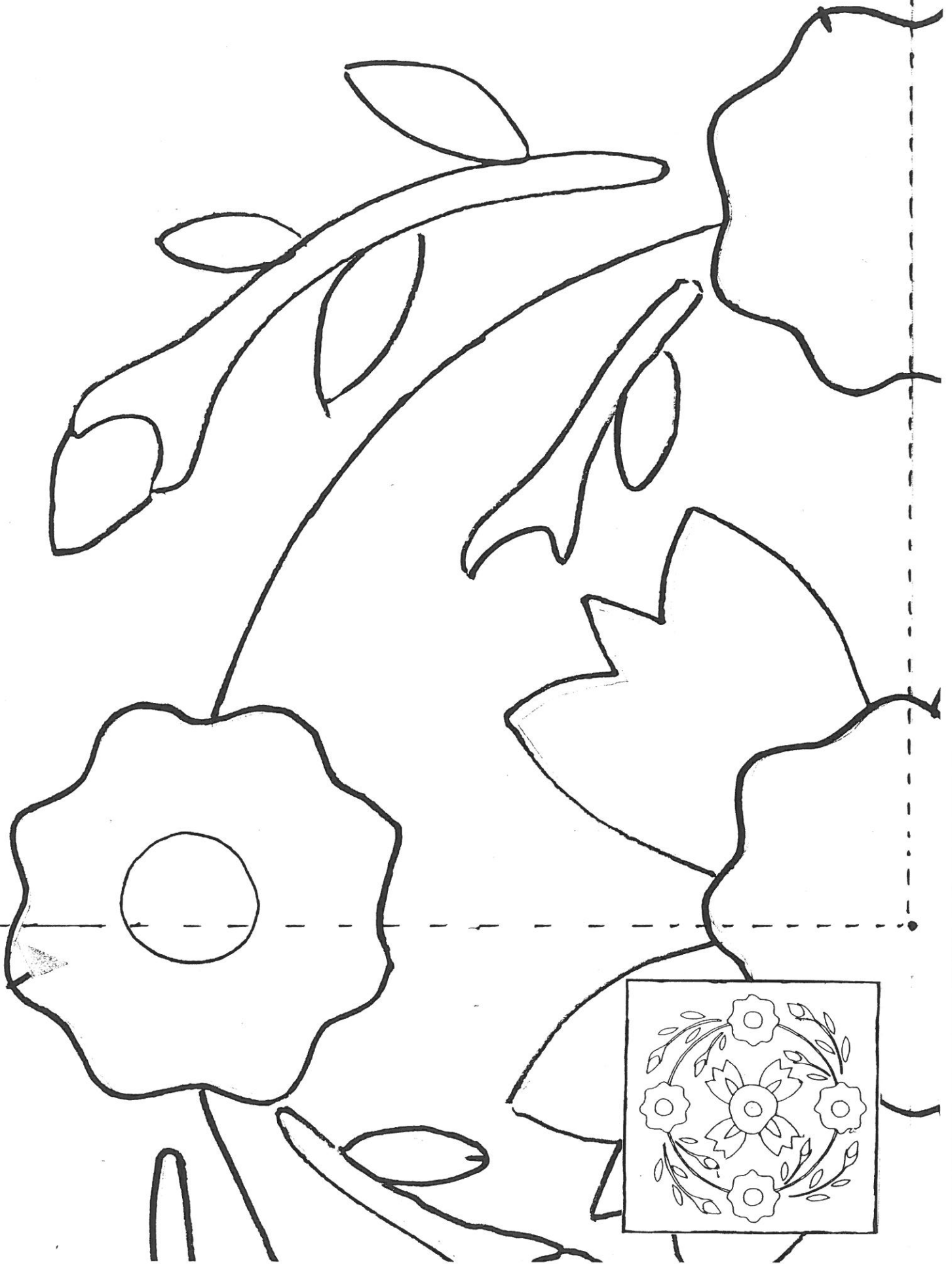

June 1990

Block of the Month

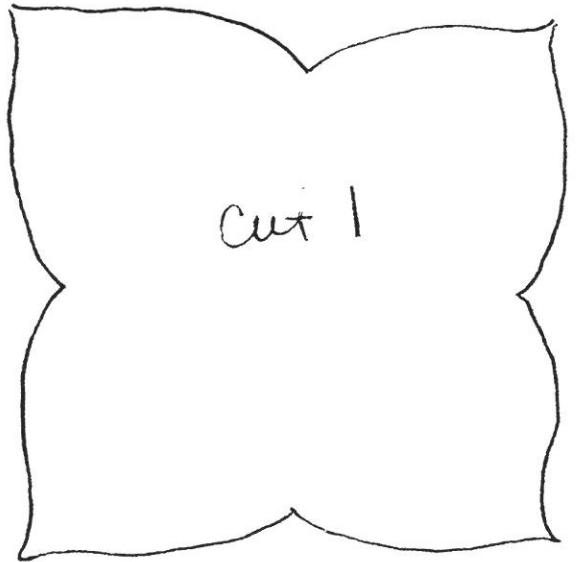
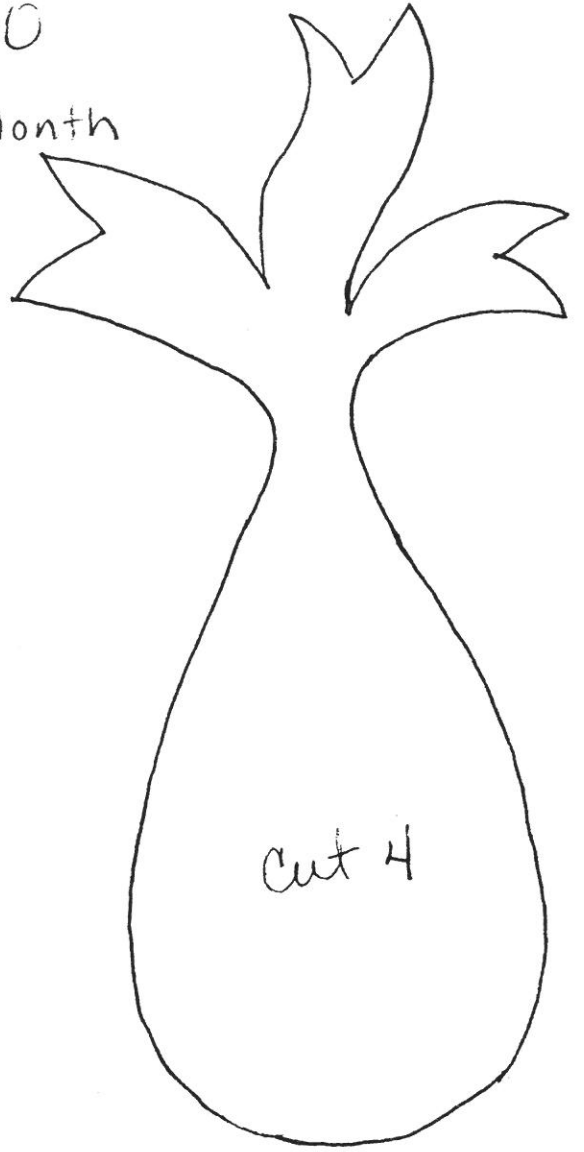
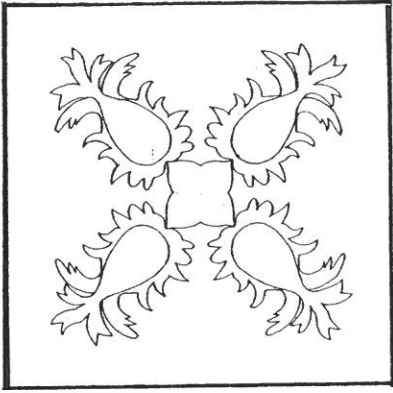

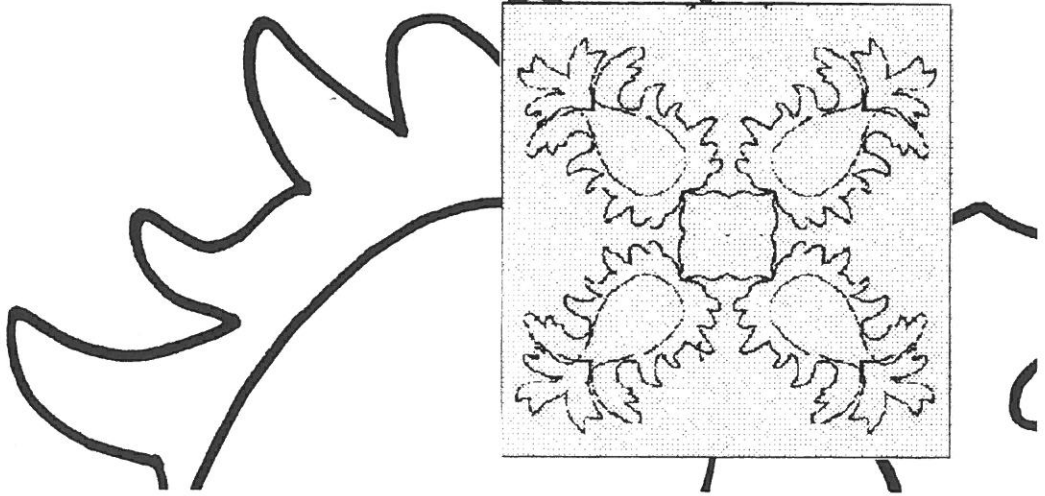
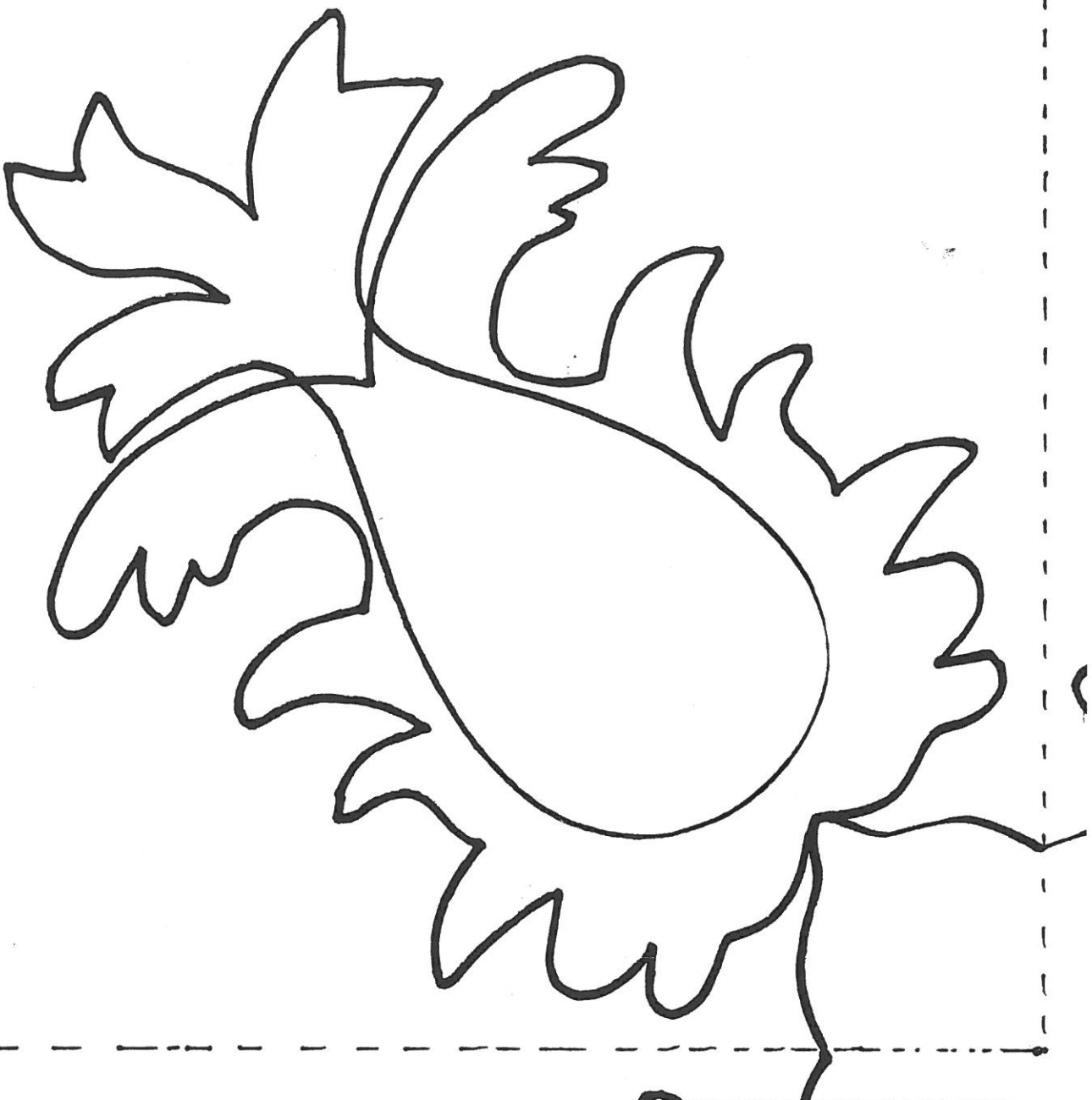

July 90

Block of the Month

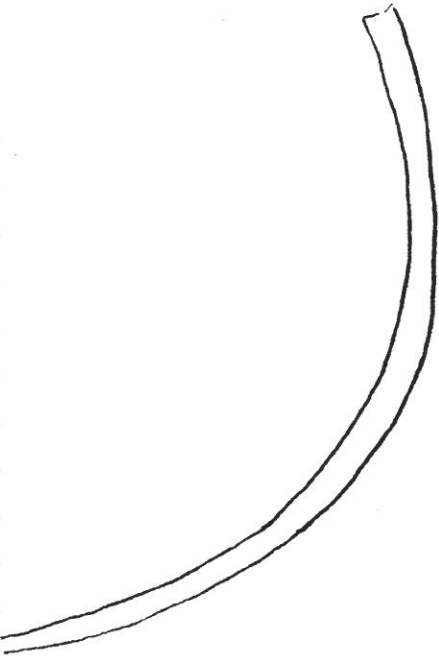
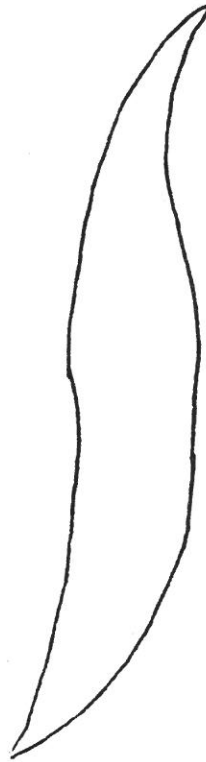
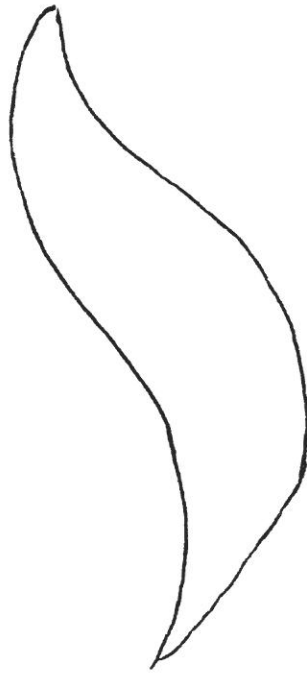
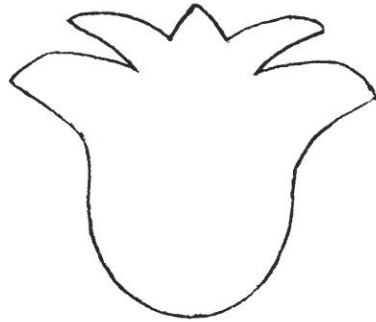
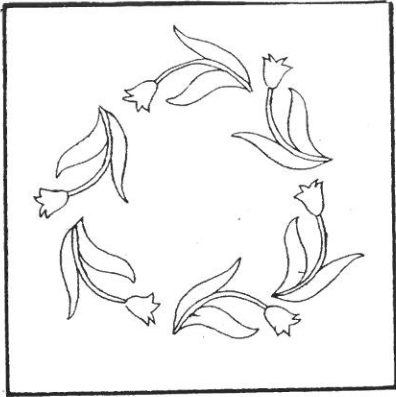

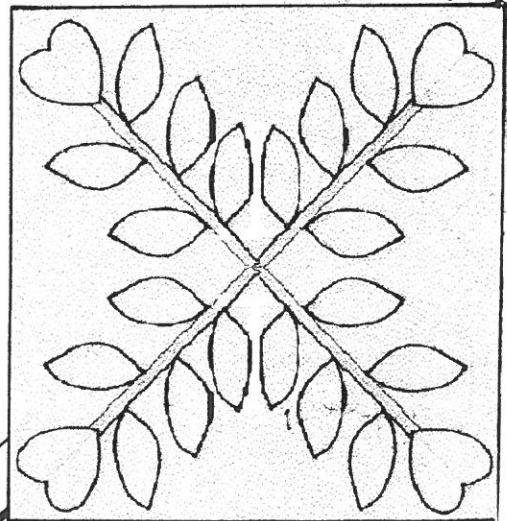
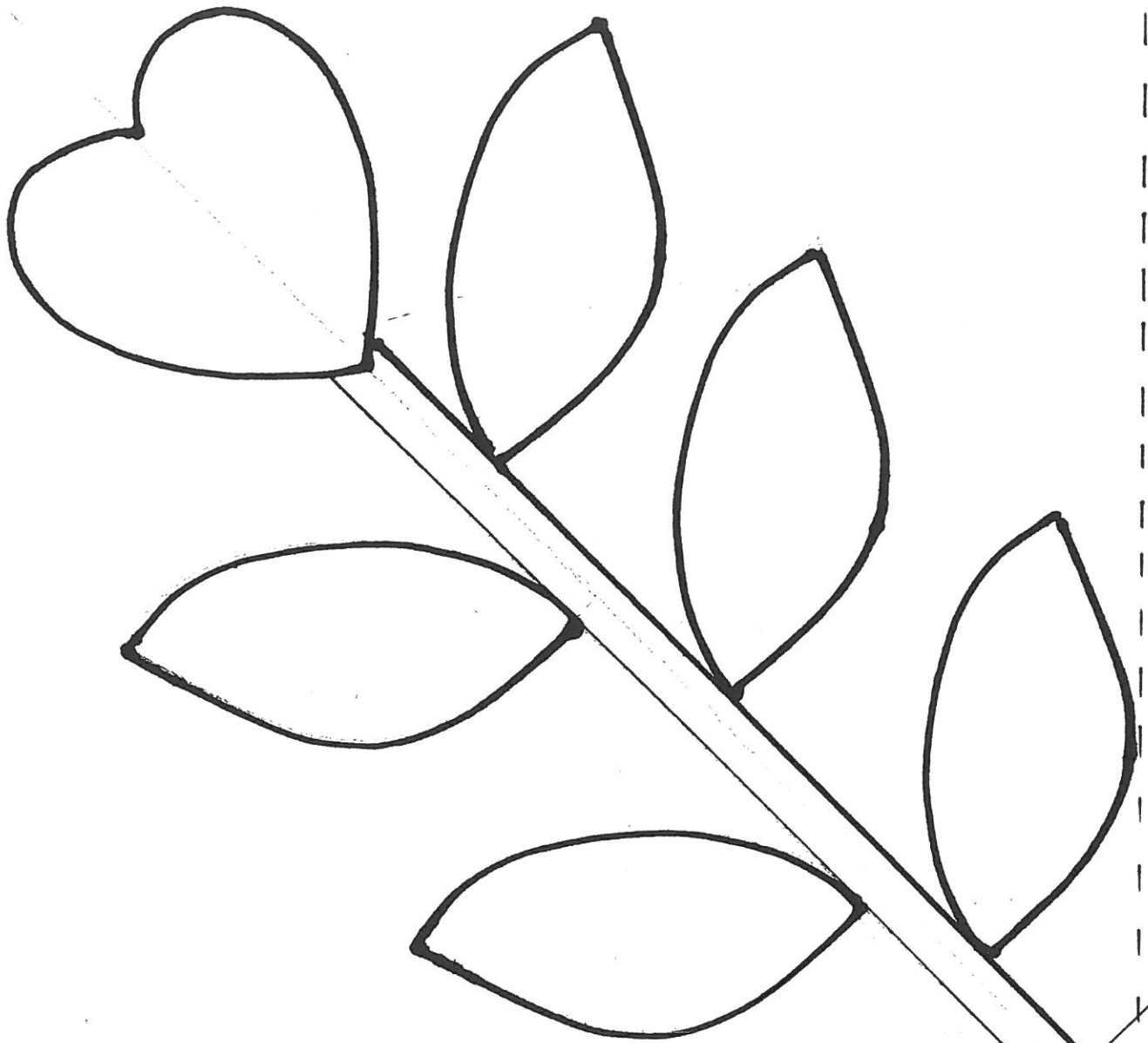

August 1990

Block of the Month

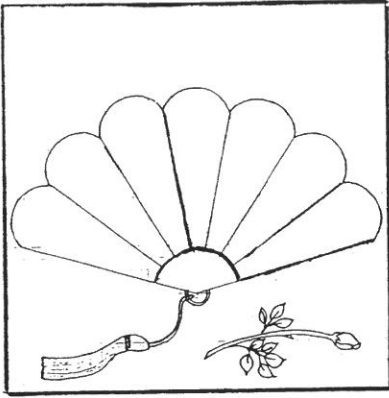

You may wish to embroider the stems for the leaves

Designed by Kim Hamby

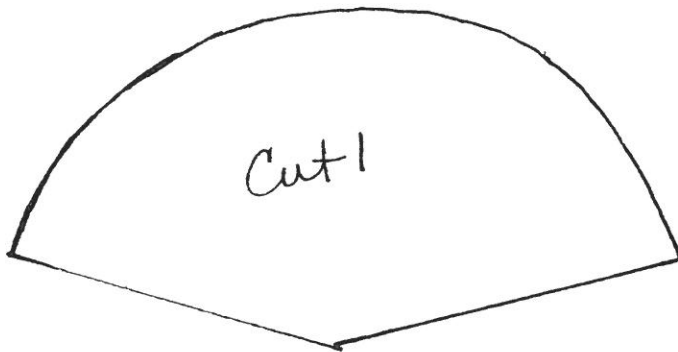
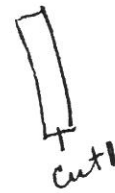
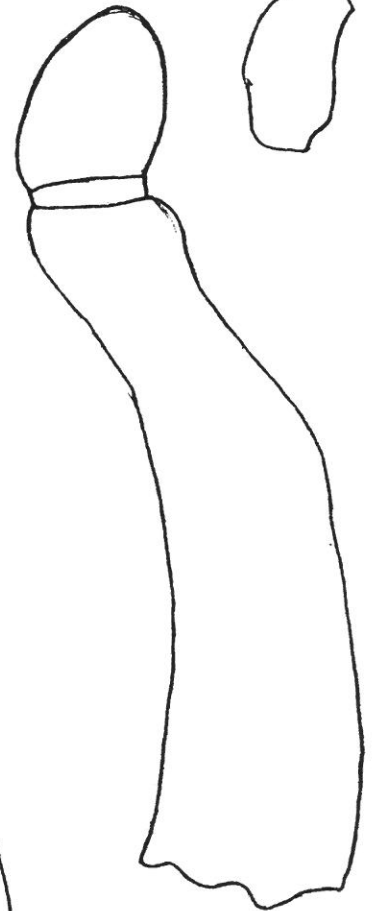
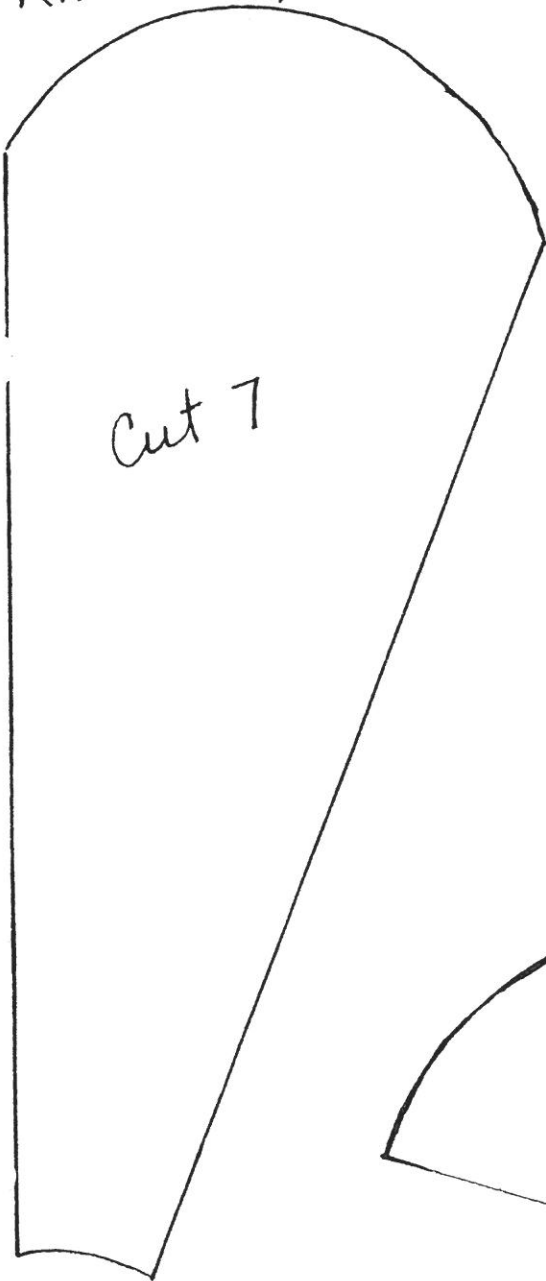

Heritage Quilters of Huntsville

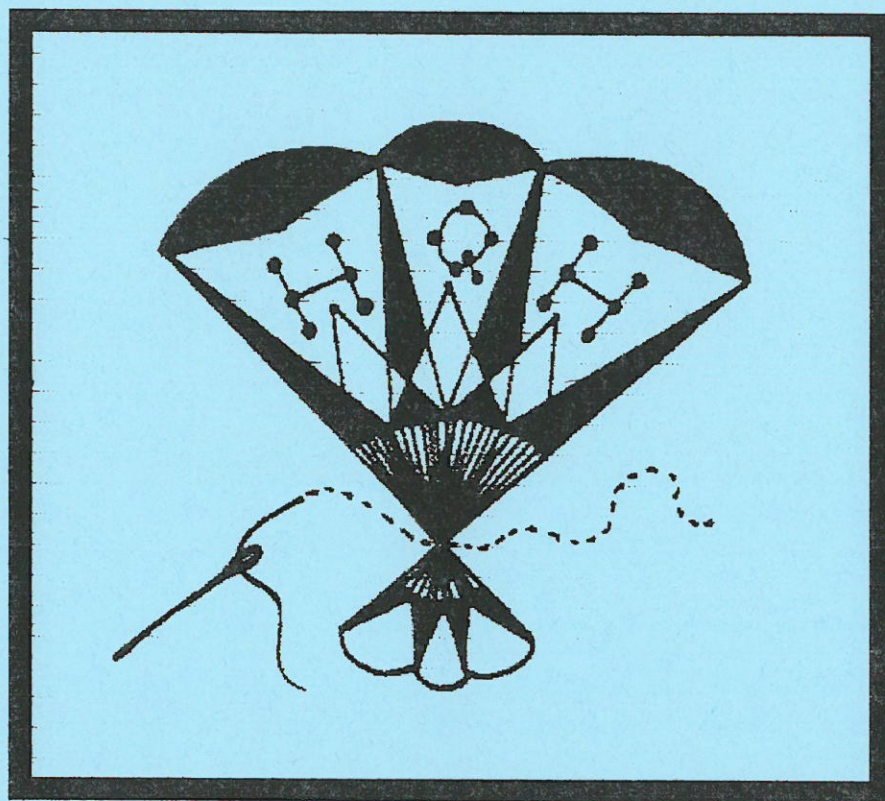

Block of the Month Patterns

1990/1991

**“Nine Patch Plus” 9” blocks
September 1990 thru August 1991
designed by Ellen Anson**

BLOCK - OF - THE - MONTH

1990/1991

- All blocks will use ONLY PATTERNS BELOW.
- CHECK FINISHED SIZE OF PLASTIC TEMPLATES AFTER CUTTING.
- ADD $\frac{1}{4}$ " SEAM ALLOWANCE (TRIM TO $\frac{1}{8}$ " AFTER SEWING ON 3" BLOCK.)

9 INCH BLOCK

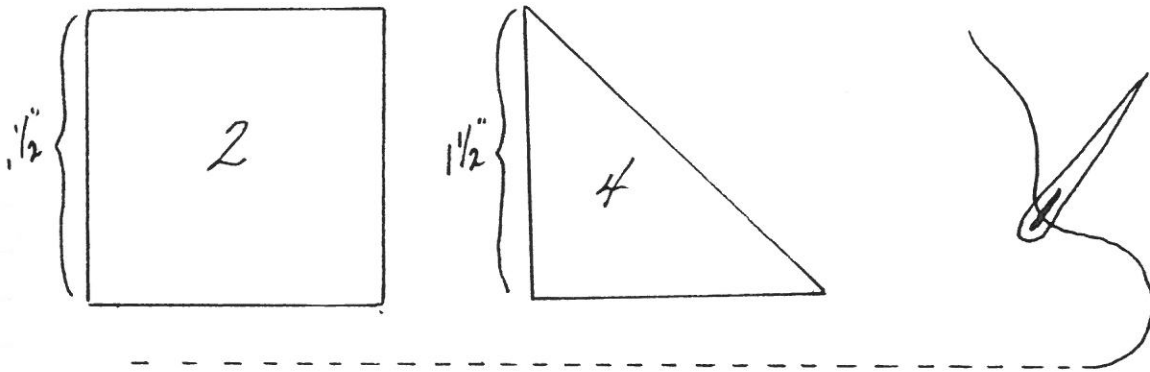
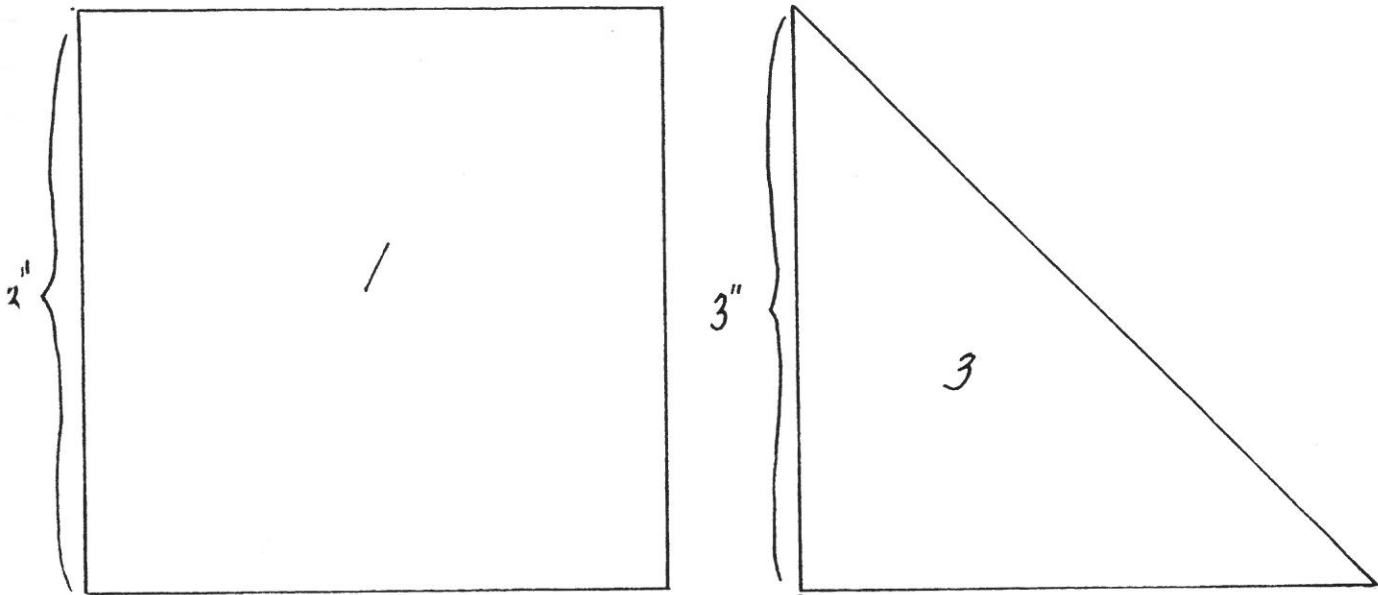

3 INCH BLOCK

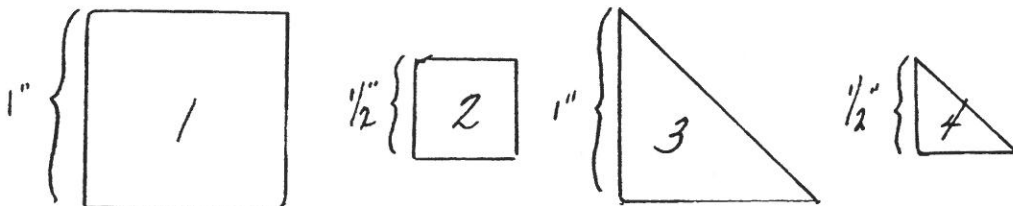

Drafted by:
Ellen Anson ☺

Block of the Month - September

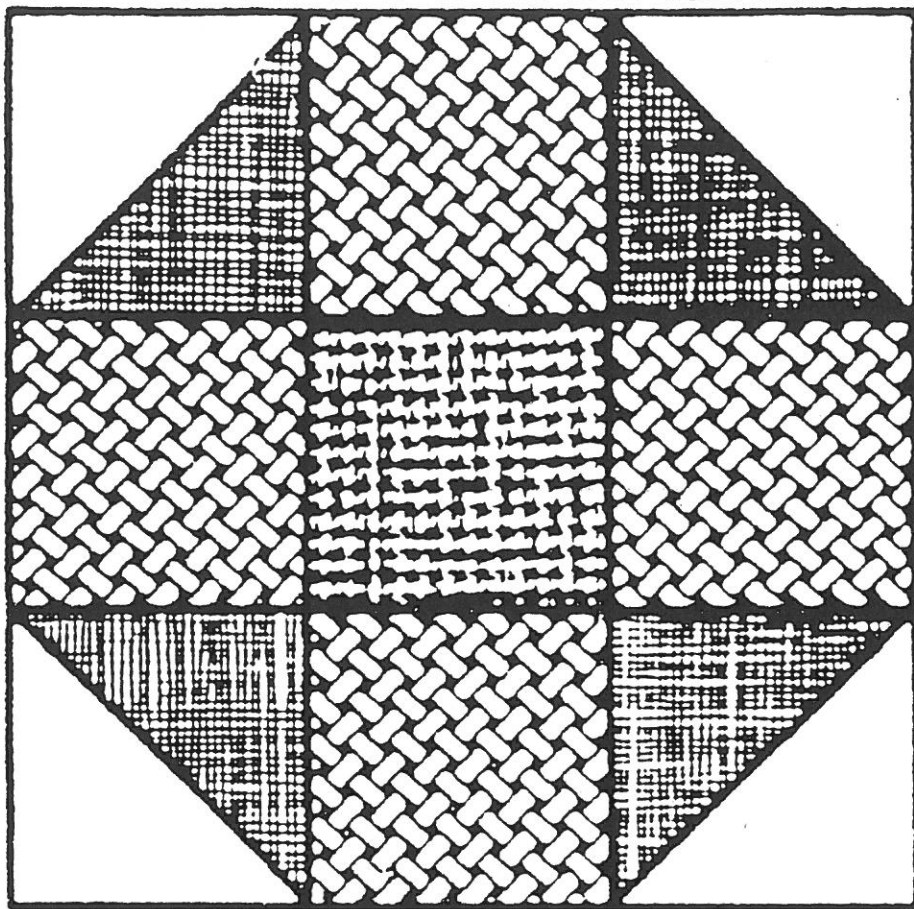

Drafted
by:
Ellen Anson ©

Cut: 4 Template #1 of one color
1 Template #1 of another color.
4 " #3 of one color + 4 in background.

QUICK PIECING TECHNIQUE FOR TRIANGLE SQUARES (3" BLOCK).

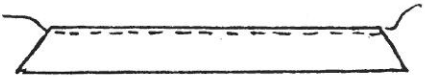
1. CUT BIAS STRIP $1\frac{1}{2}'' \times 10''$ OF TWO FABRICS.
2. SEW TOGETHER ON LONG SIDE USING $\frac{1}{8}''$ SEAM. 
3. OPEN OUT. PRESS SEAM TO DARKER FABRIC.
4. USE #1 TEMPLATE (1" SQUARE) AND PLACE ON STRIP AS SHOWN.
CUT 4 OF THESE SQUARES, BEING SURE TO ADD SEAM ALLOWANCES.

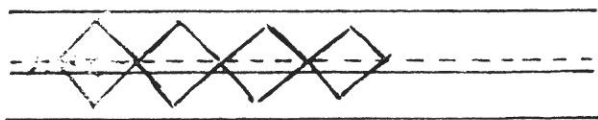

Block of the Month - October

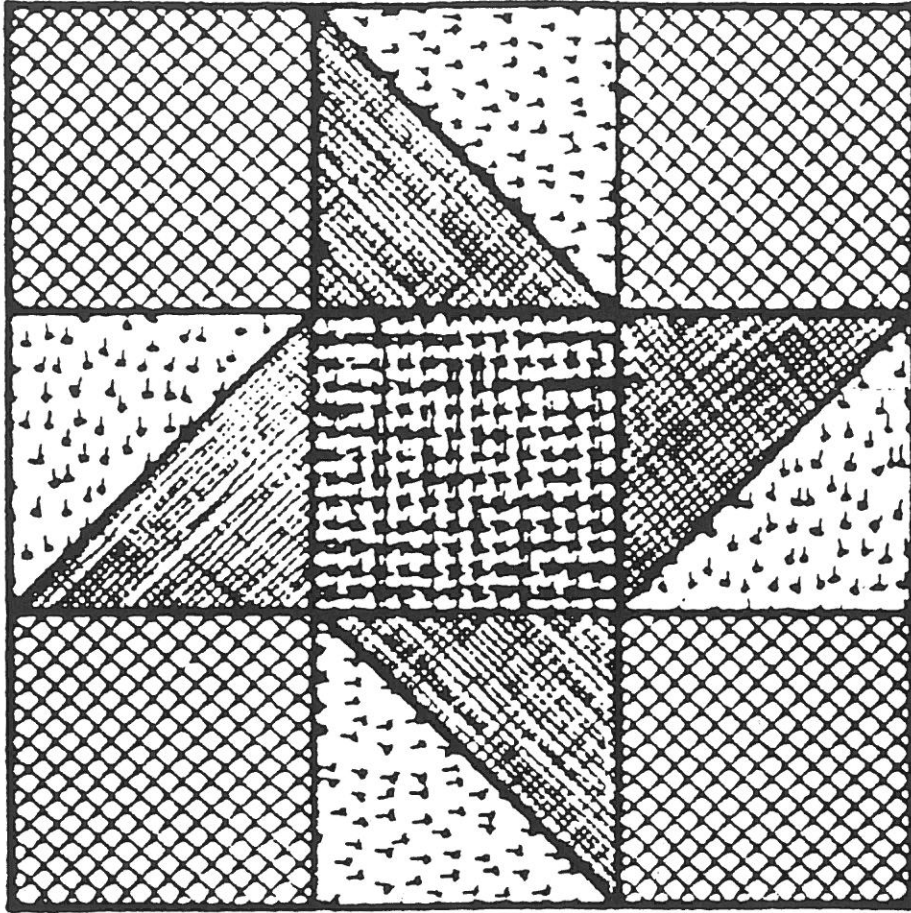

Drafted
by:
Ellen Anson ☺

Cut - 4 Template #1 of one color
1 Template #1 of another color
4 " #3 of one color + 4 in background.

- This pattern is merely a rearrangement of last month's! Again, use quick piecing technique for triangle squares.
- Check accuracy of finished 3" block using 3" square template (#1) of 9" block. Redraw outer seam lines if necessary.

Block of the Month - November

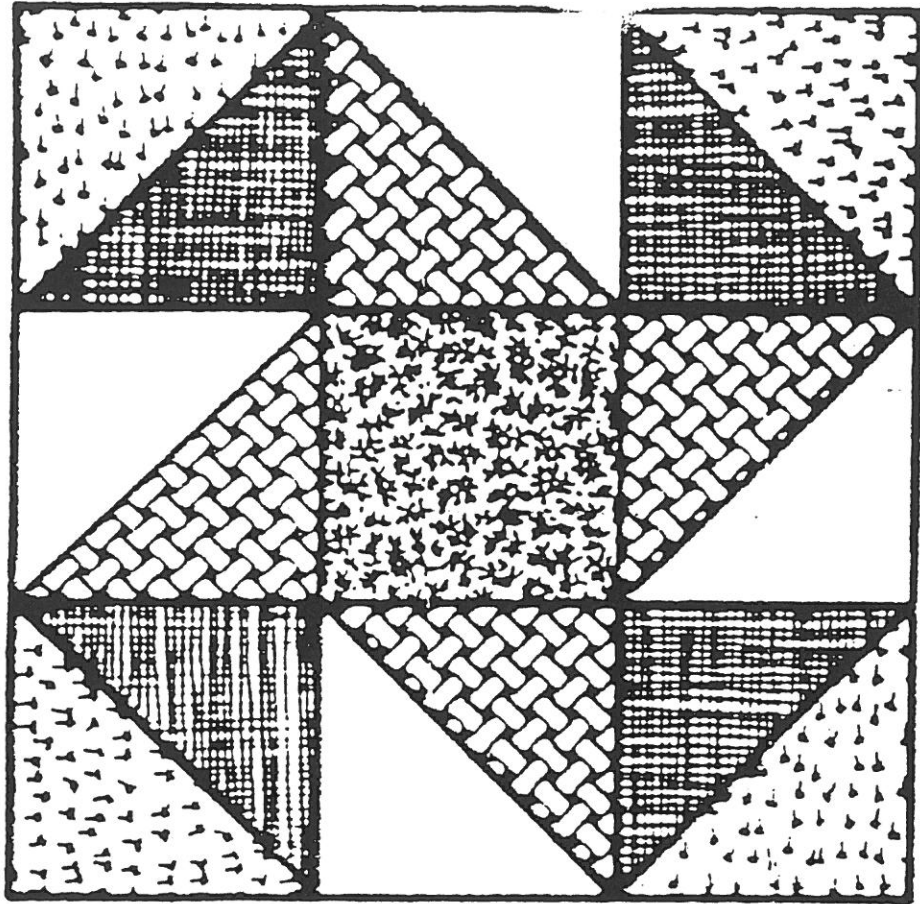

Drafted
by:
Ellen Anson ☺

Cut 1 Template # 1
4 Template # 3 in each of 4 colors.

Suggested settings + yardage:

I suggest using 6 fabrics:

2 fabrics for 9" square

2 fabrics for 3" square

2 " to share between them.

Yardage: 2 yds outside border } use in
1 3/4 yds sashing } piecing
1/2 yd - fabrics for 9" blocks } blocks
1/4 yd - fabrics for 3" blocks } also

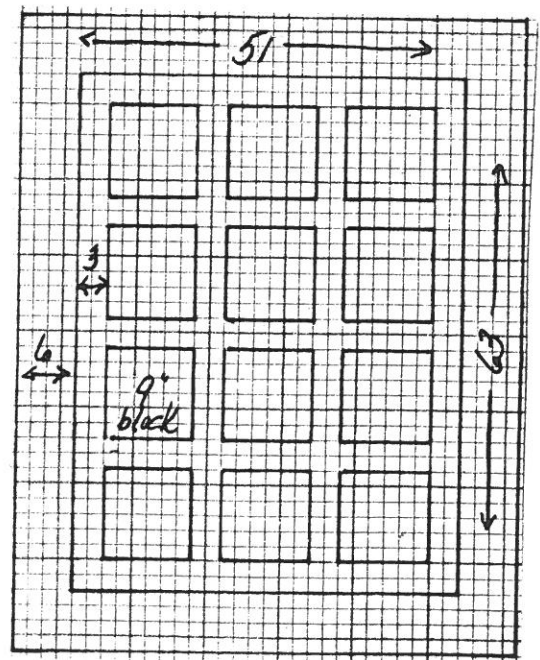

Block of the Month - December S

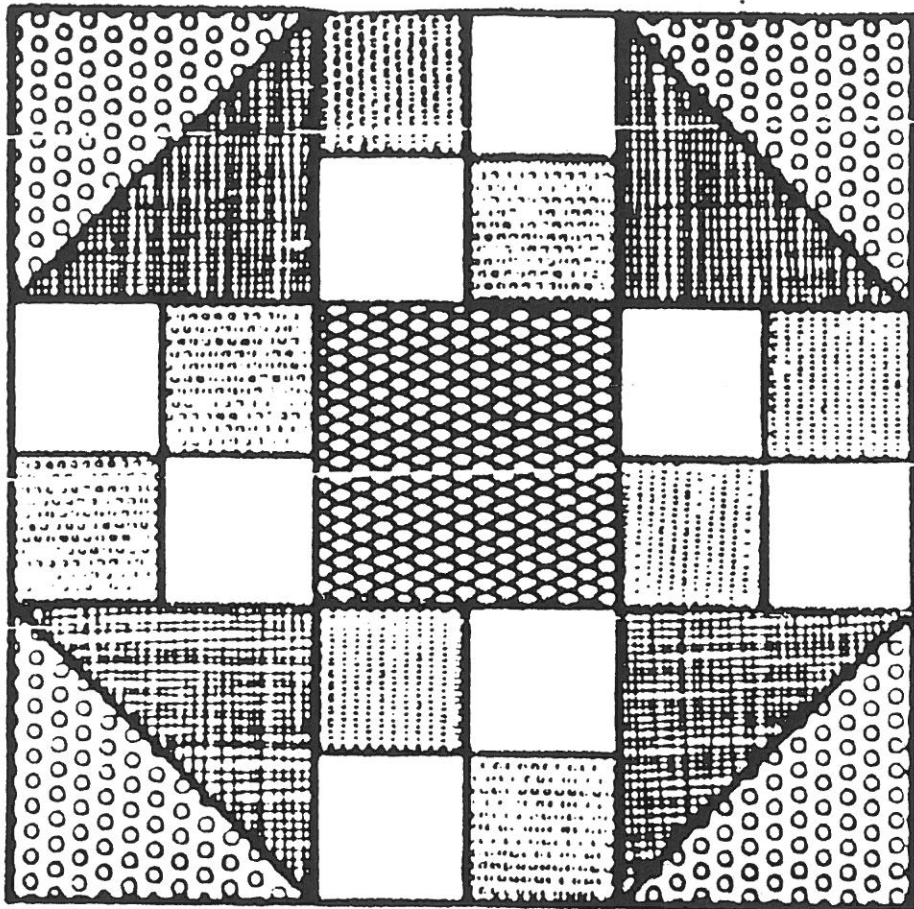

Drafted
by:
Ellen Anson ©

- Cut 1 Template #1
4 each of 2 fabrics Template #3
8 each of 2 fabrics Template #2

Quick Piecing Technique for 4 patch square (3" square)

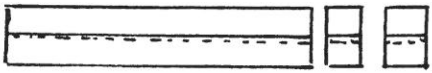
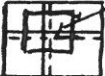
1. Cut 1" x 8" straight strips of 2 fabrics.
2. Sew together along long side using $\frac{1}{8}$ " seam. Open
3. Mark template #3 in 4ths \rightarrow 
4. Cut strip into 1" segments. 
5. Sew 2 segments together making 4 patch square. 
6. Lay #3 Template over square, matching seam markings and mark seam allowances. Trim to $\frac{1}{4}$ ".

Block of the Month - January

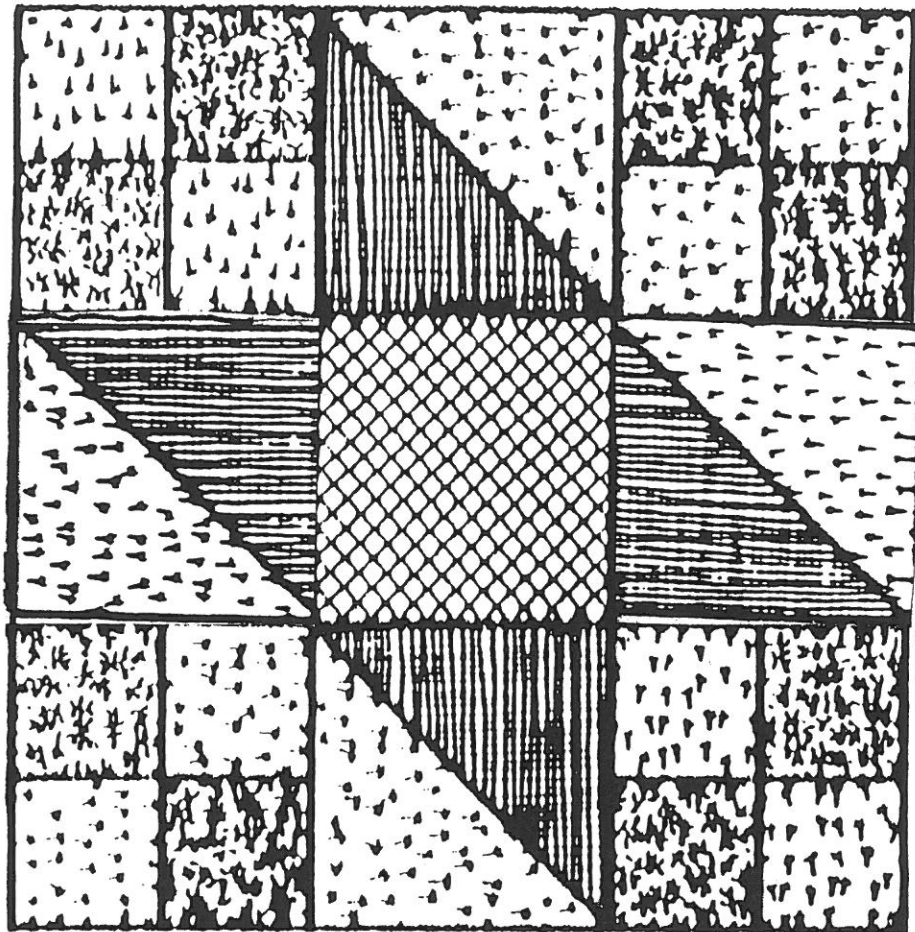

Drafted
by:
Ellen Anson ☺

Cut: 1 Template #1
8 Template #2 in each of 2 colors
4 Template #3 in each of 2 colors

Follow quick piecing technique for 4 patch square given last month, and quick piece triangle squares as explained in September. - Nothing new here - just a chance to practice up on techniques already tried!

Block of the Month - February

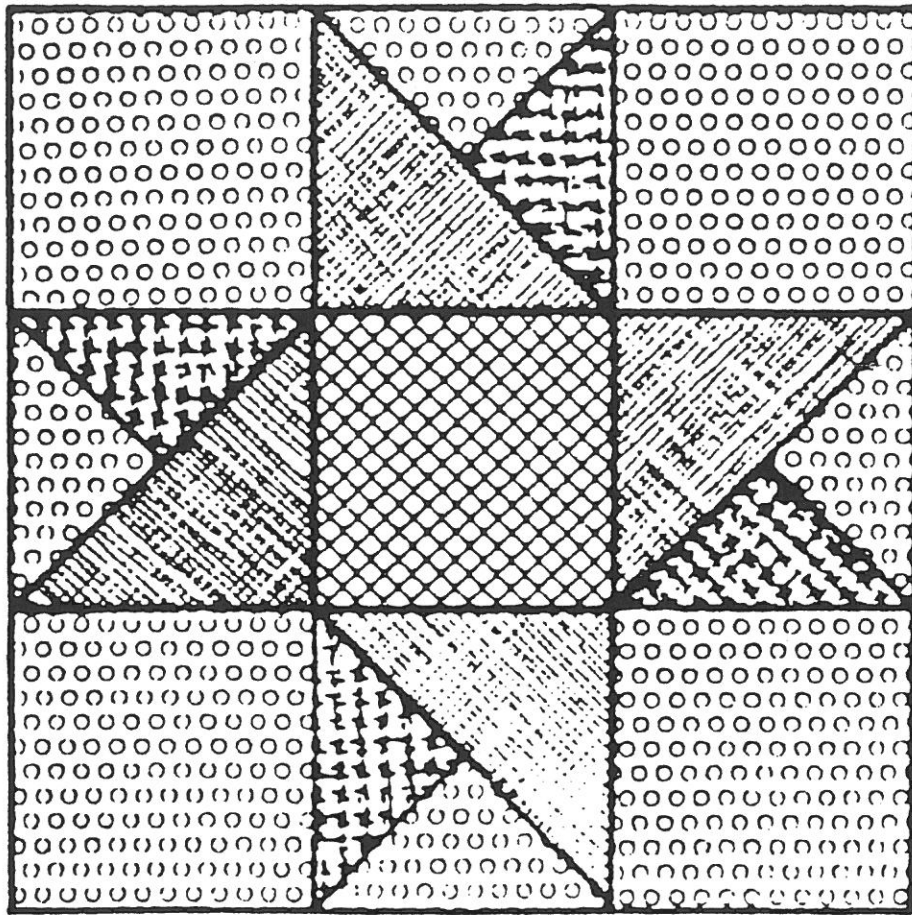

Drafted
by -
Ellen ☺
Anson

Quick Stipping 3-Triangle block

1. Cut bias strips of fabrics A & B that are at least $1\frac{1}{2}$ " wide. Sew together using $\frac{1}{8}$ " seam.
2. Open & press. Cut into 4 $2\frac{1}{2}$ " lengths.
3. Cut a bias strip of C that is 2" wide. Cut this strip into $2\frac{1}{2}$ " lengths.
4. Sew A-B units to C units.
5. Lay 1" square template on completed unit and cut.

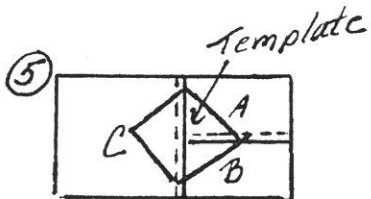
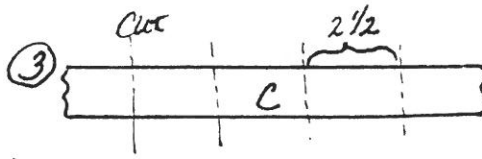
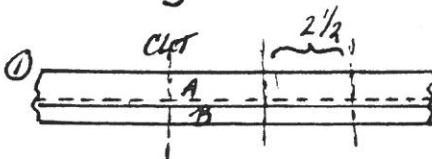
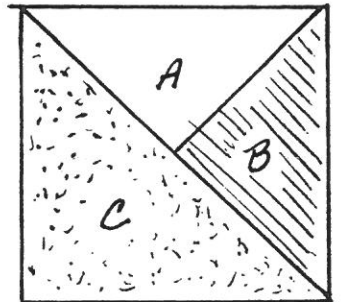

Block of the Month - March

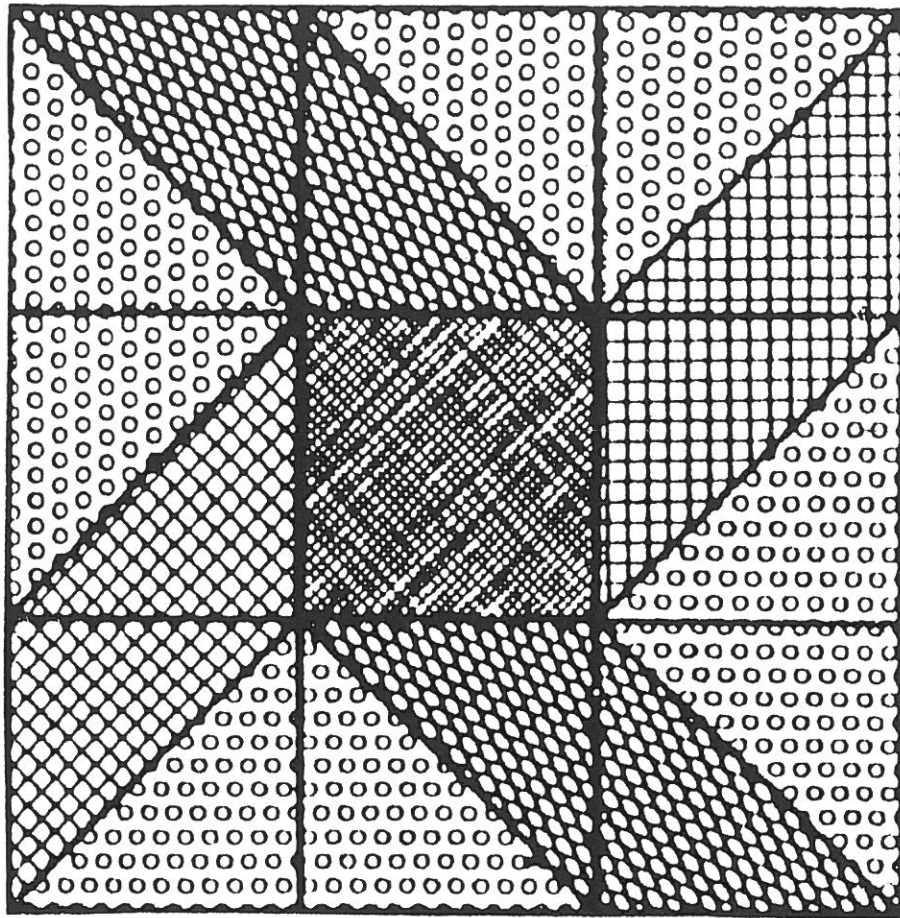

Drafted
by
Ellen ©
Anson

If you haven't yet tried quick-piecing a mini-block - here's your chance. This windmill takes you back to September's lesson. Try it!

Cut: 1 Template #1

8 Template #3 in 1 color

4 Each of 2 colors of Template #3

Block of the Month - April

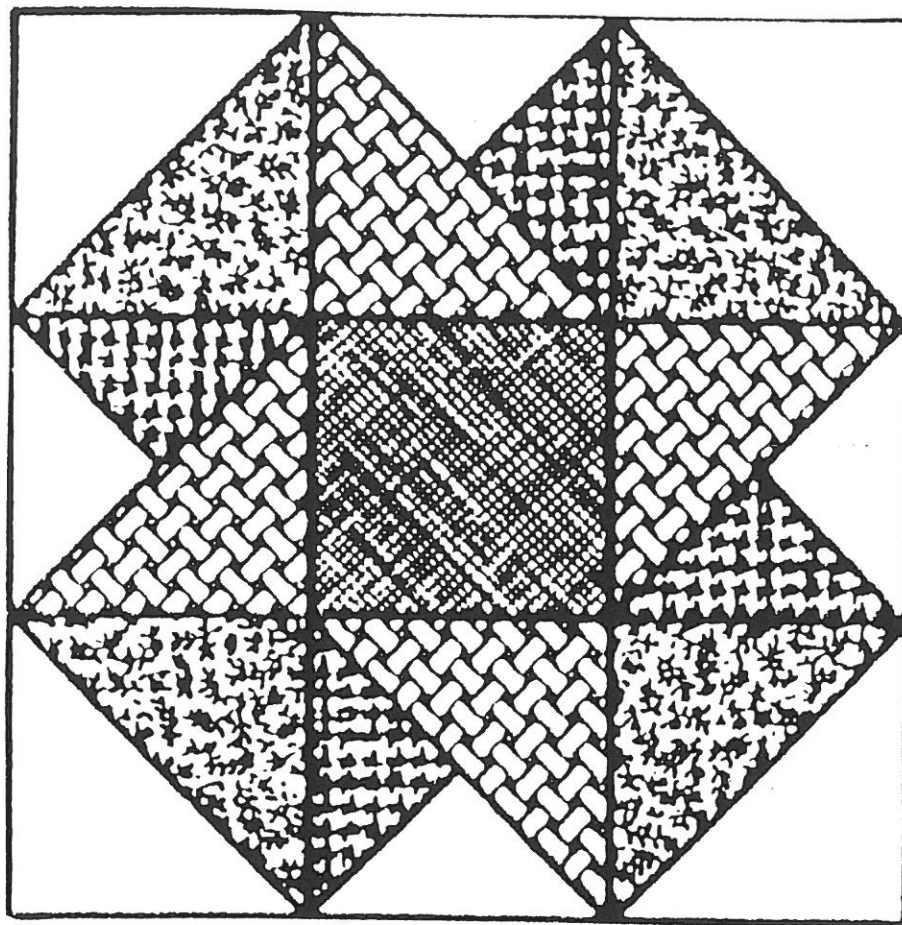

Drafted
by:
Ellen ☺
Anson

Cut -

- 1 Template #1
- 4 " #3 of background
- 4 " #4 " "
- 4 Template #3 in each of 2 fabrics
- 4 " #4 in another fabric.

This block contains both 2 & 3 triangle squares. Look for directions on September & February's B.o.M.

Block of the Month - May

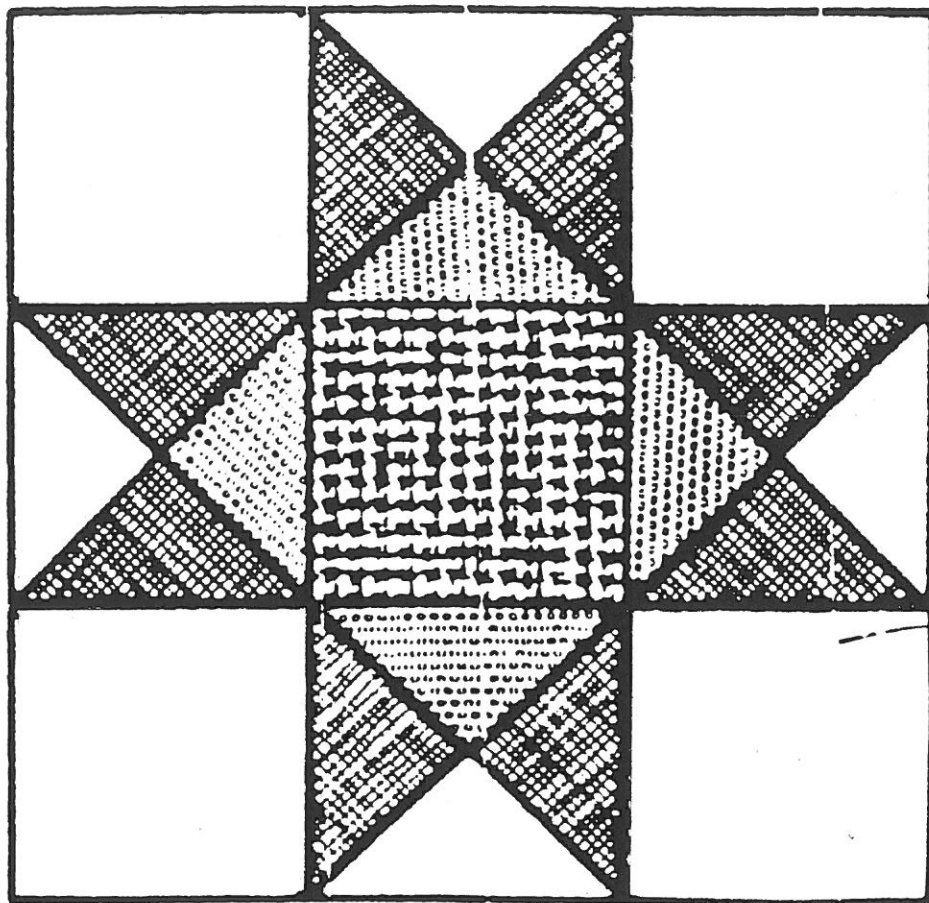

Drafted
by:
Ellen
Anson

- Cut 1 Template #1 of one fabric and
4 " " of background.
4 Template #3 " "
4 " #4 of background
4 " " another color
8 " " contrast

Good ol' "Ohio Star"! The four triangle squares are strip pieced for the 3" block as follows:

1. Cut 2 1" squares of one fabric, 1 of background and one of contrast. Piece the background square to one of 1st fabric and contrast to other square.

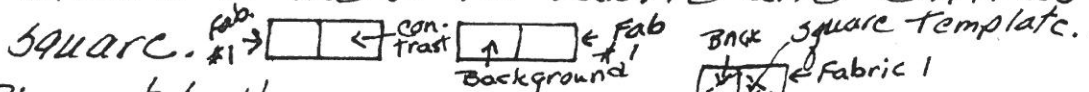

2. Piece together as shown:
3. Lay 1" square diagonally + draw seam - cut.

Block of the Month - June

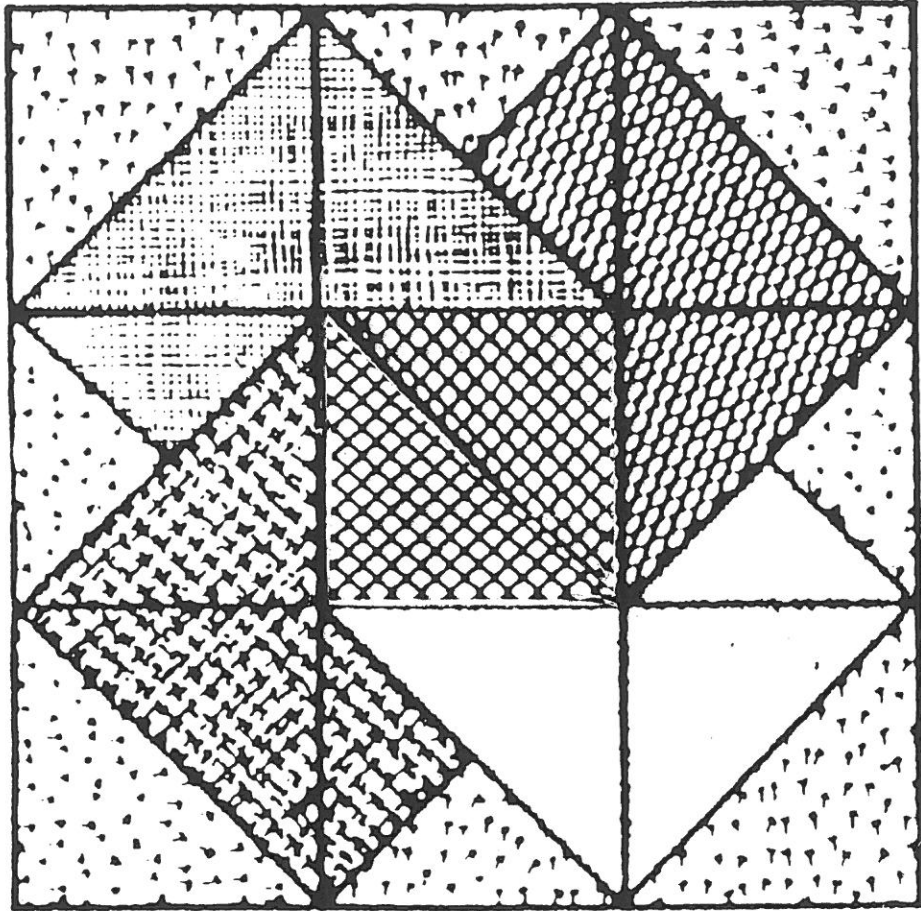

Drafted
by:
Ellen ☺
Anson

Cut: 1 Template #1
2 each of 4 Fabrics of Template #3
4 Template #3 of background
1 each of 4 fabrics of Template #4
4 Template #4 of background.

Same pattern as April - different
color arrangement.

Block of the Month - July

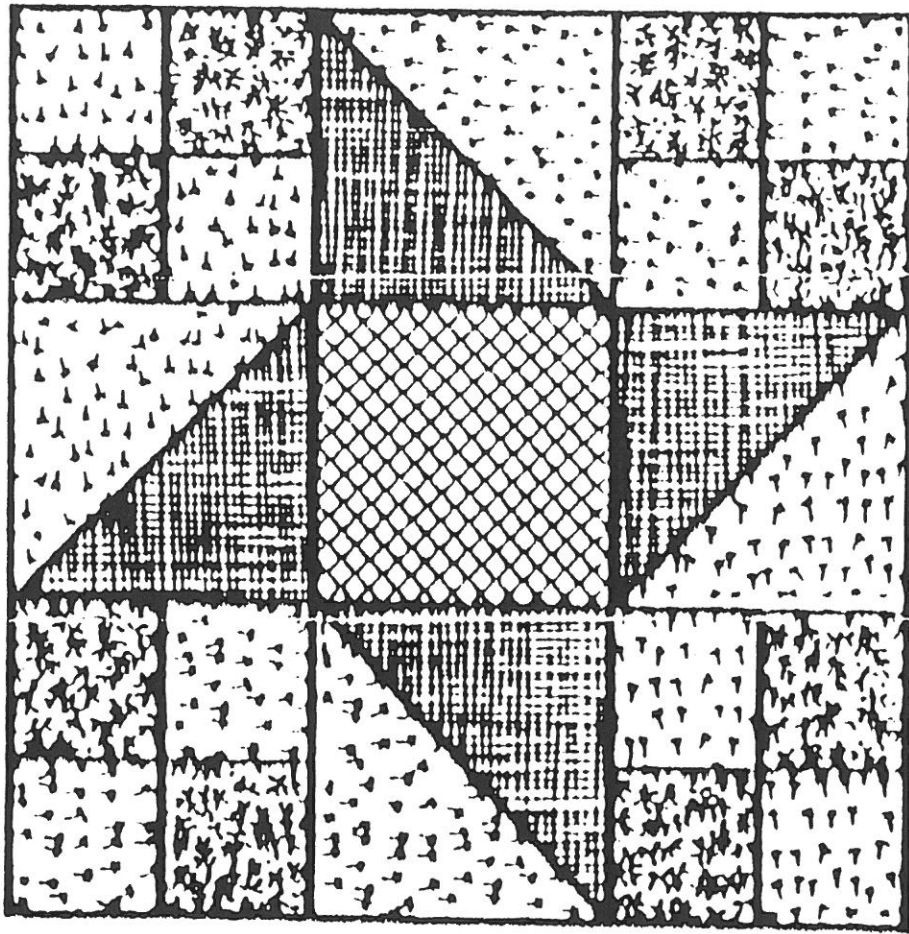

Drafted
by:
Ellen ☺
Anson

Cut - 1 Template #1
4 Template #3 in background
4 " " in contrast
8 " #2 in background
8 " " contrast

I'm giving you a break this month with a very easy one!

See December's block for piecing the 4-patch squares.

Block of the Month - August

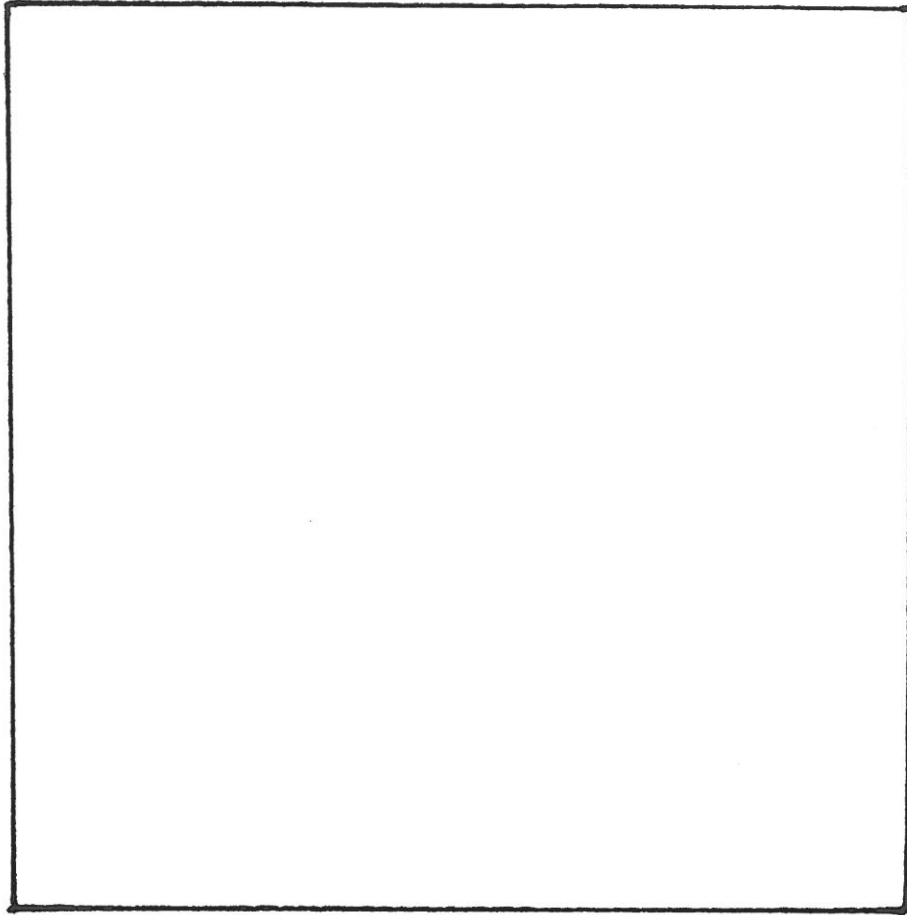

[Signature]
Drafted
by:
Ellen ©
Anson

No, your eyes aren't deceiving you and my printer didn't break down. I've designed 11 blocks for you - see if you can come up with one of your own. Here are the rules:

1. Must be a 9-patch with a solid - as in un-pieced-middle square.
2. Use only 4 templates given in September.

There are countless possibilities remaining - let's see how many different ones we come up with!

1990 / 1991

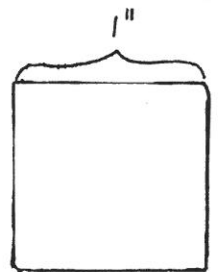
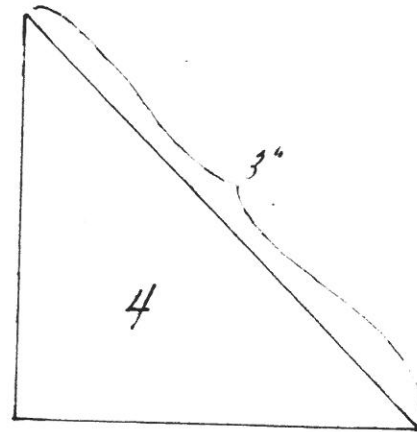
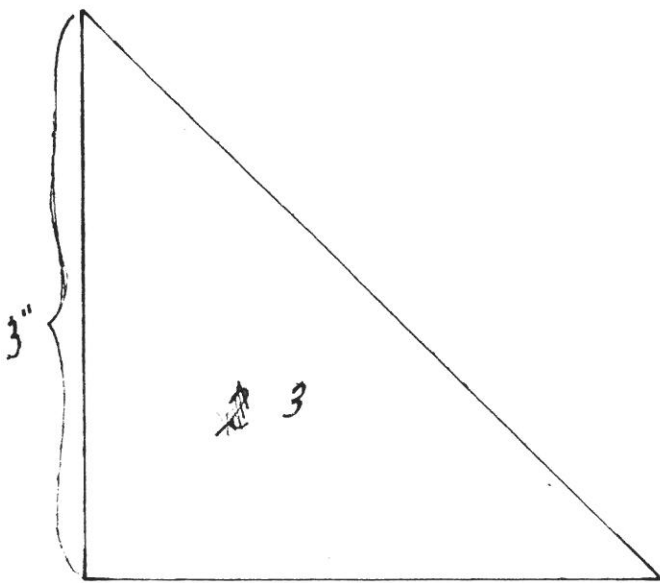
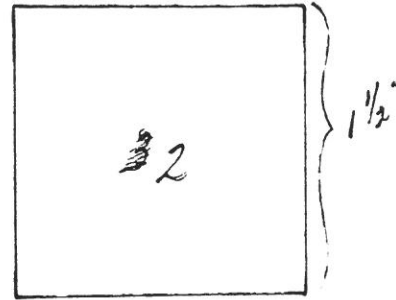
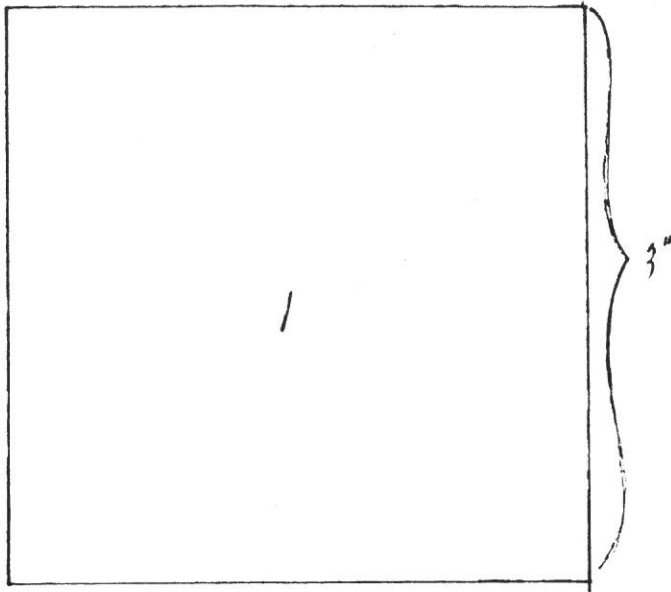

used as pattern
in quick
stripping 3"
blocks.

Machine Piecing: Add $\frac{1}{4}$ " seam allowance to all sides before cutting templates. Cut just along inside of line. Check machine for accurate $\frac{1}{4}$ " seam line. Line up raw edges even, sew $\frac{1}{4}$ " in from outside edges.

Hand Piecing: Cut templates size shown without adding $\frac{1}{4}$ " seam allowance. Cut fabric approximately $\frac{1}{4}$ " larger than seam line. Line up seam lines & sew. Outer edges may not necessarily match up.

Quick Piecing 2/triangle squares - 3" block.

- 1. Cut one strip of each color on the bias that is 1 1/2" wide.

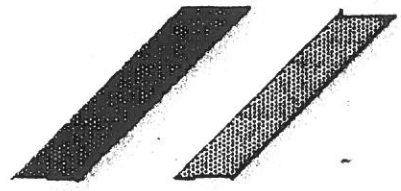

- 2. Sew together along one long side using 1/4" seam allowance. Trim seam to 1/8" and press.



- 3. Lay the 1" square #1 template on the wrong side (seam up) so that the seam goes through a diagonal of the square. Trace around template. Cut out, leaving a scant 1/4" seam.

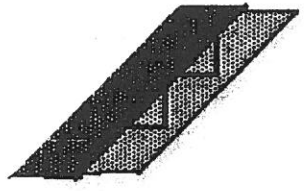

HERITAGE QUILTERS
OF HUNTSVILLE

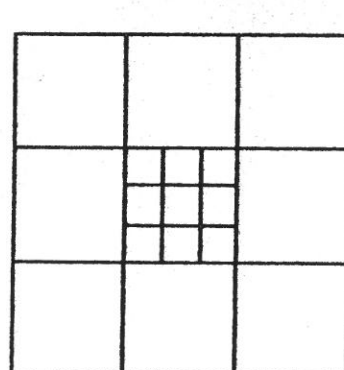
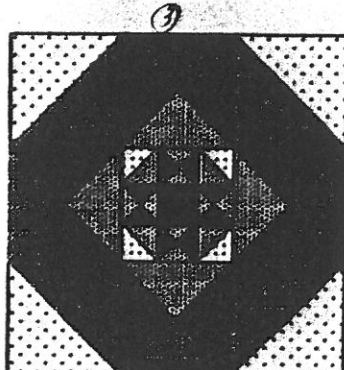
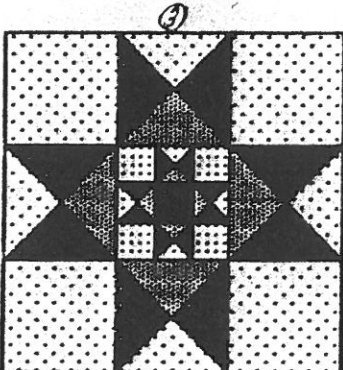
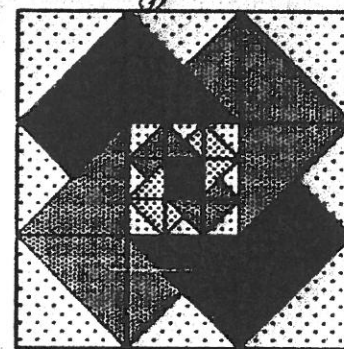
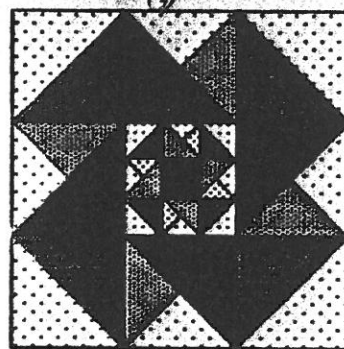
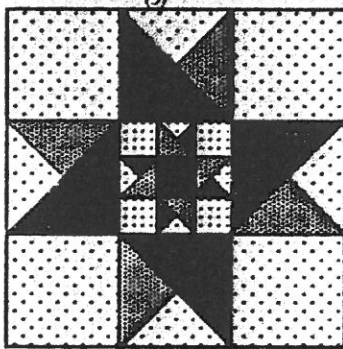
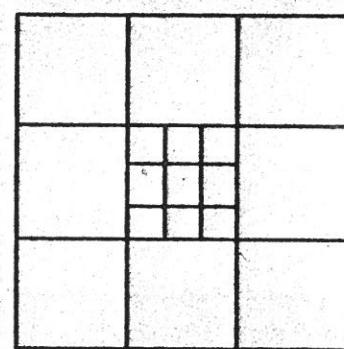
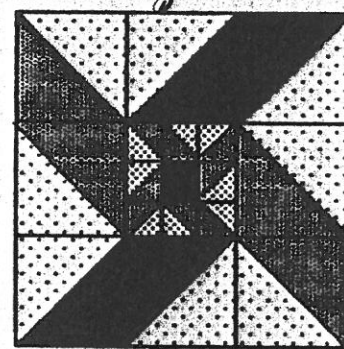
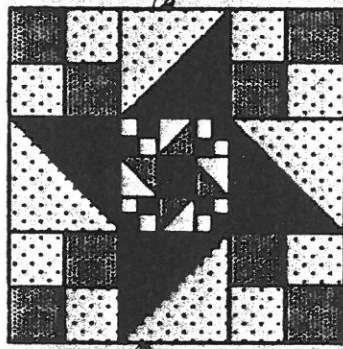
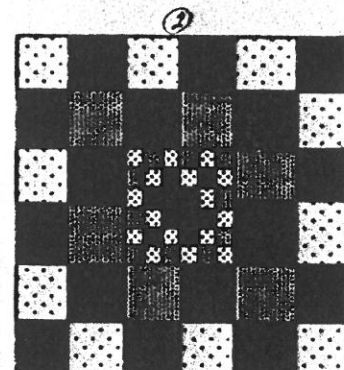
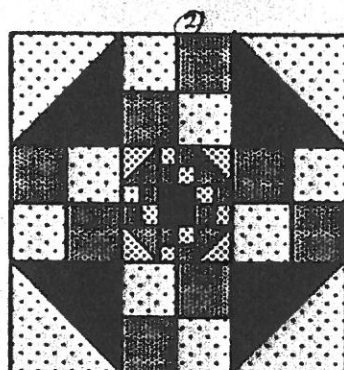
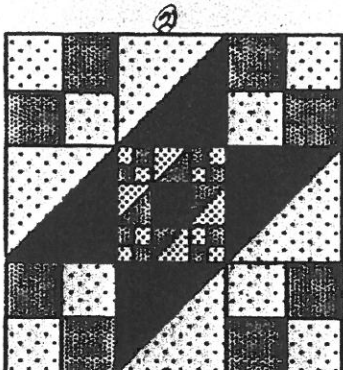
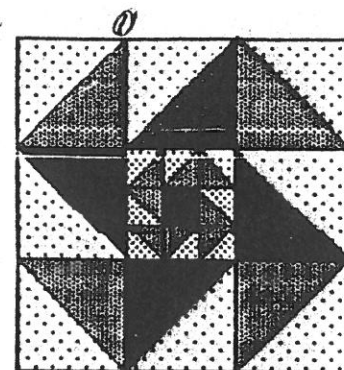
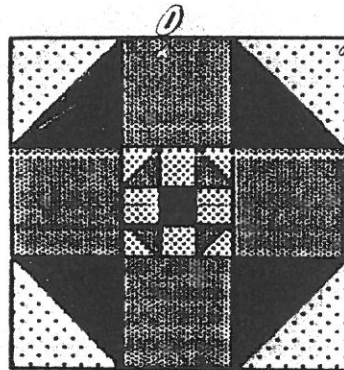
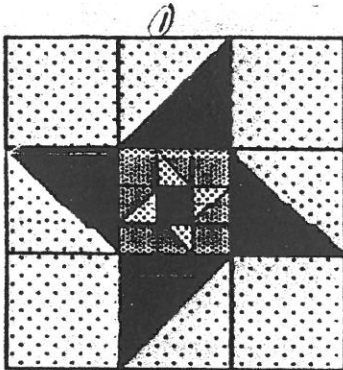

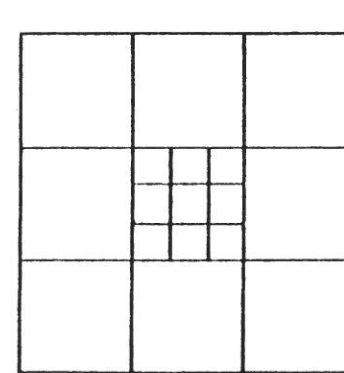
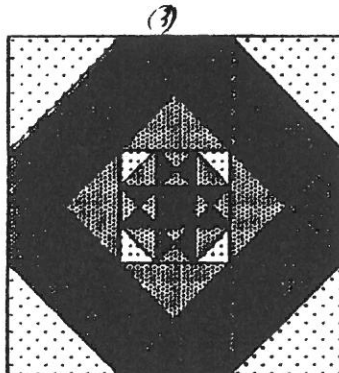
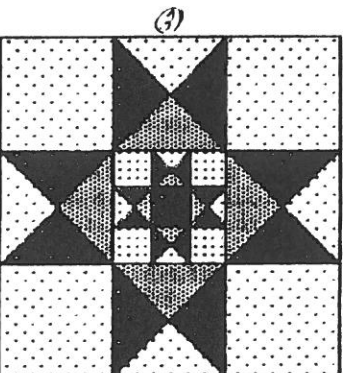
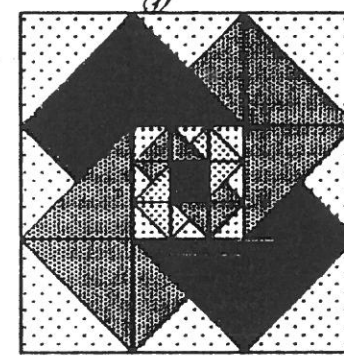
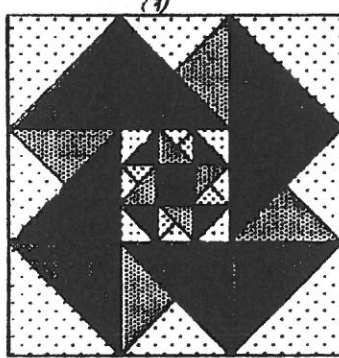
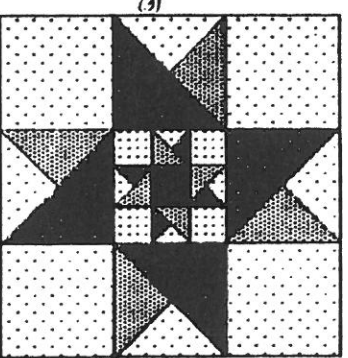
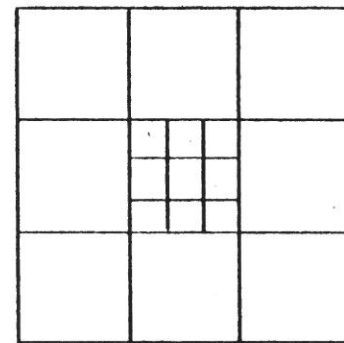
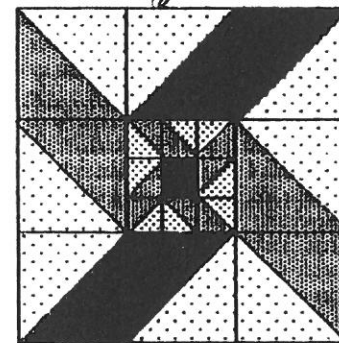
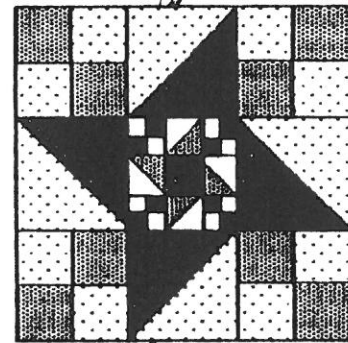
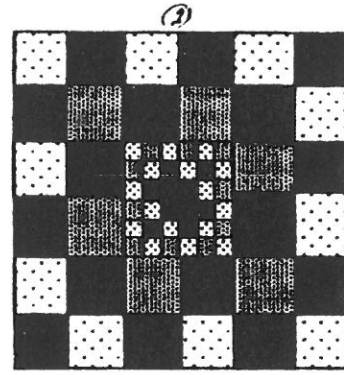
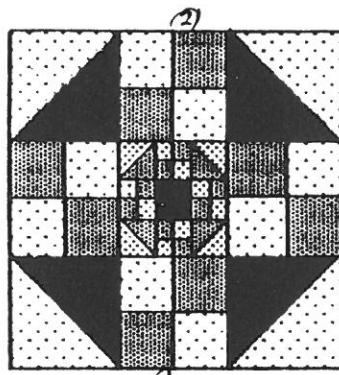
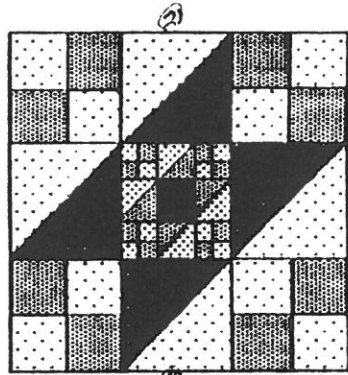
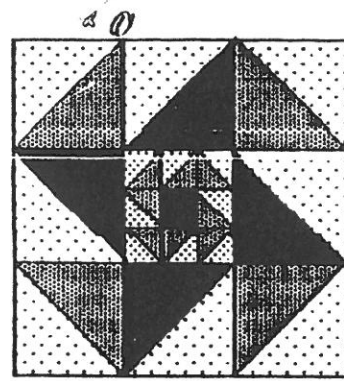
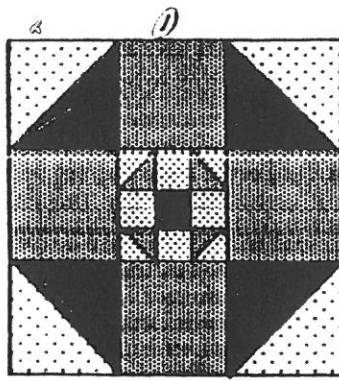
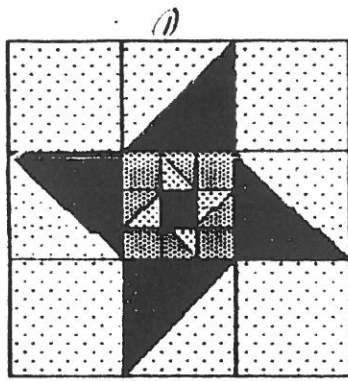

Heritage Quilters of Huntsville

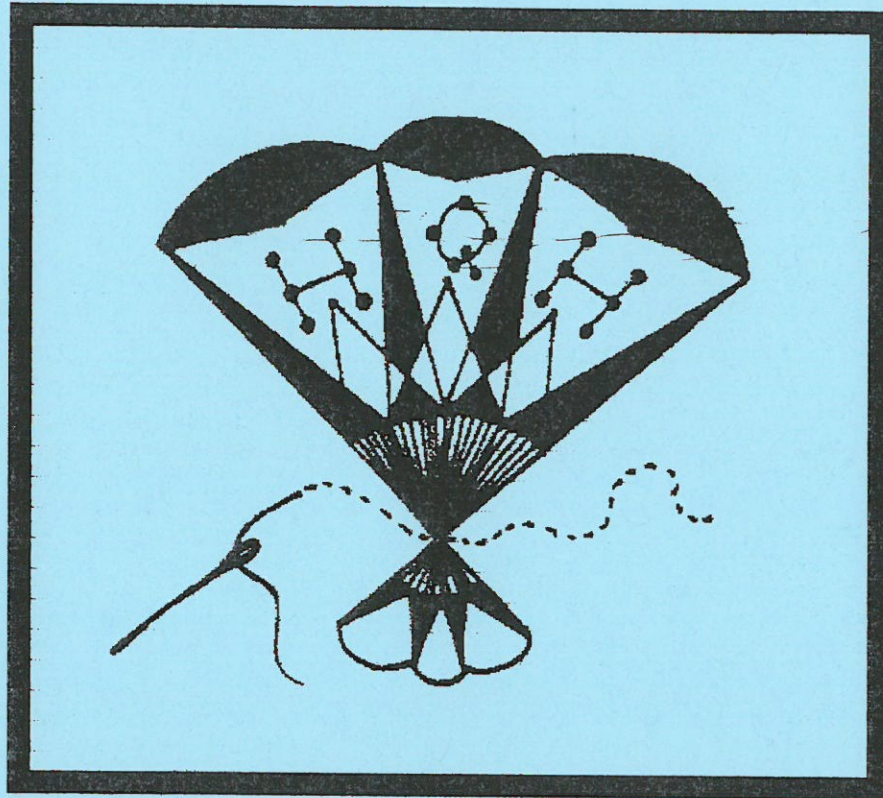

Block of the Month Patterns

1991/1992

**12" pieced star blocks
September 1991 thru August 1992
designed by Linda Worley**

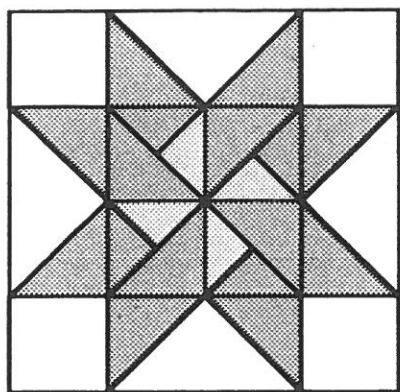

Heritage Quilters of Huntsville
Block of the Month

September Star

must add seam
allowance on all
pattern pieces

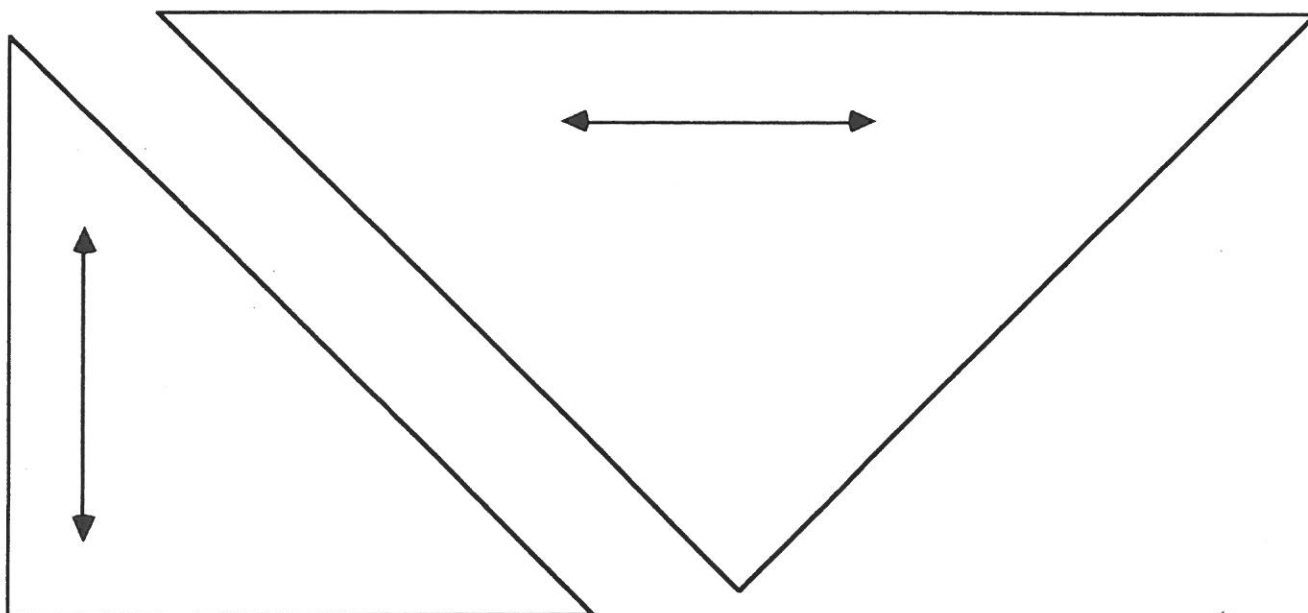
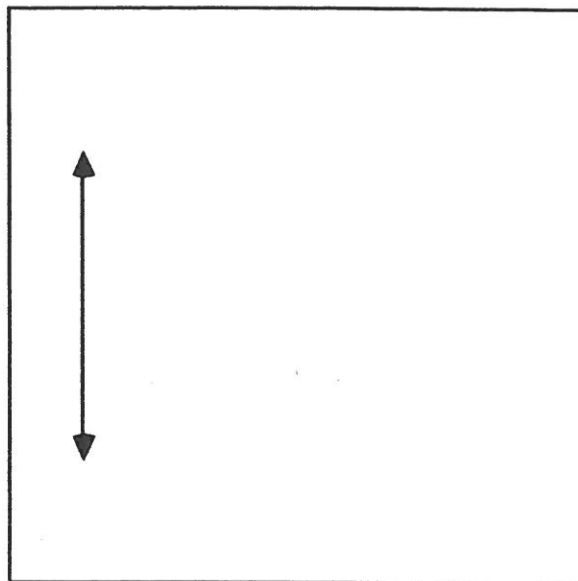
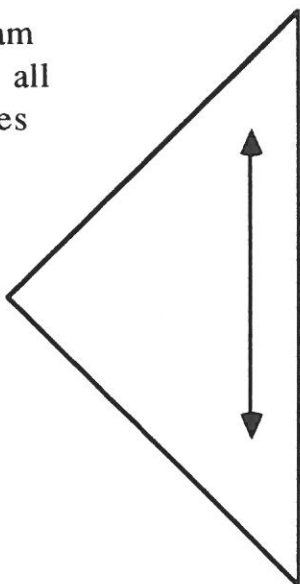

Heritage Quilters of Hunstville Block of the Month

Octoberfest

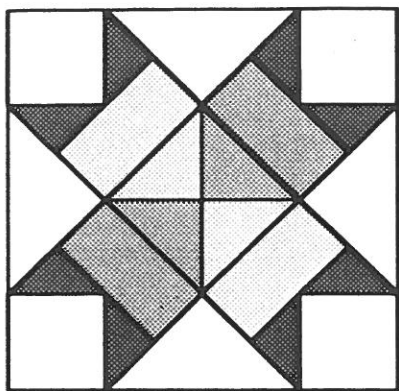

must add seam allowance on all pattern pieces

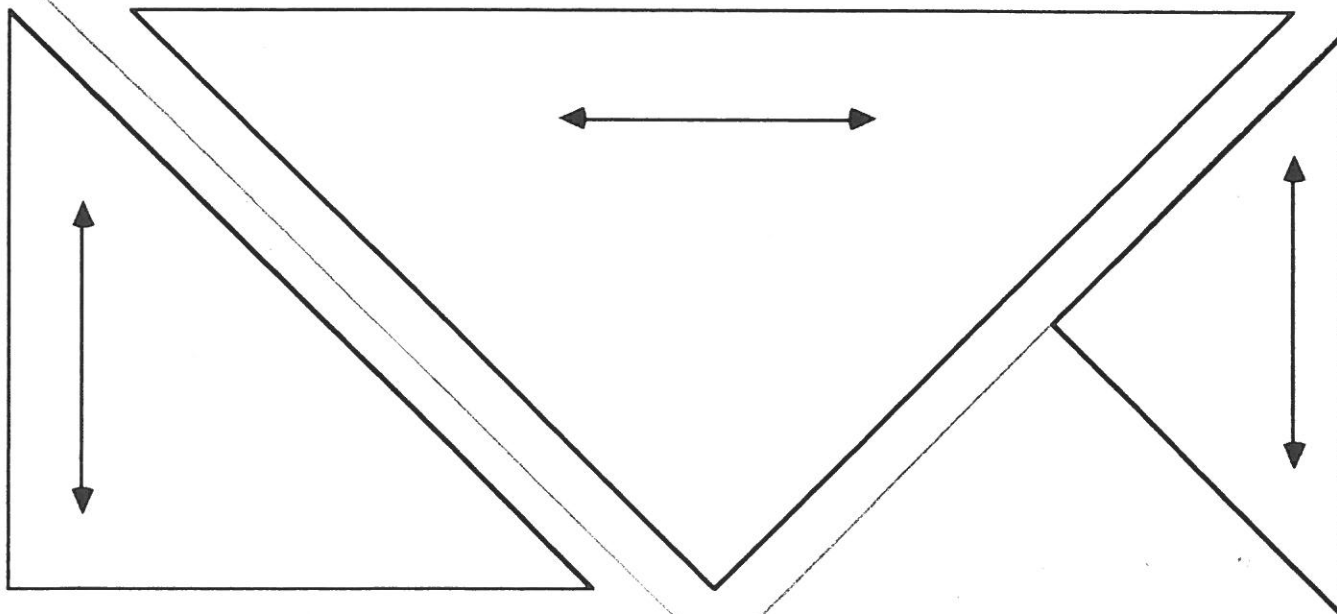
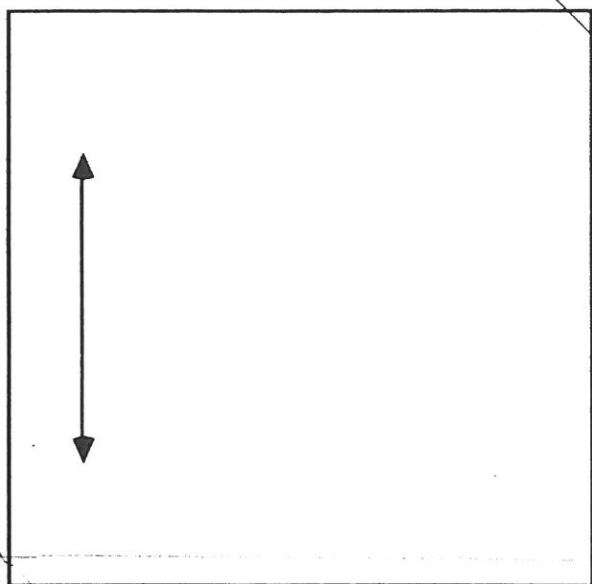
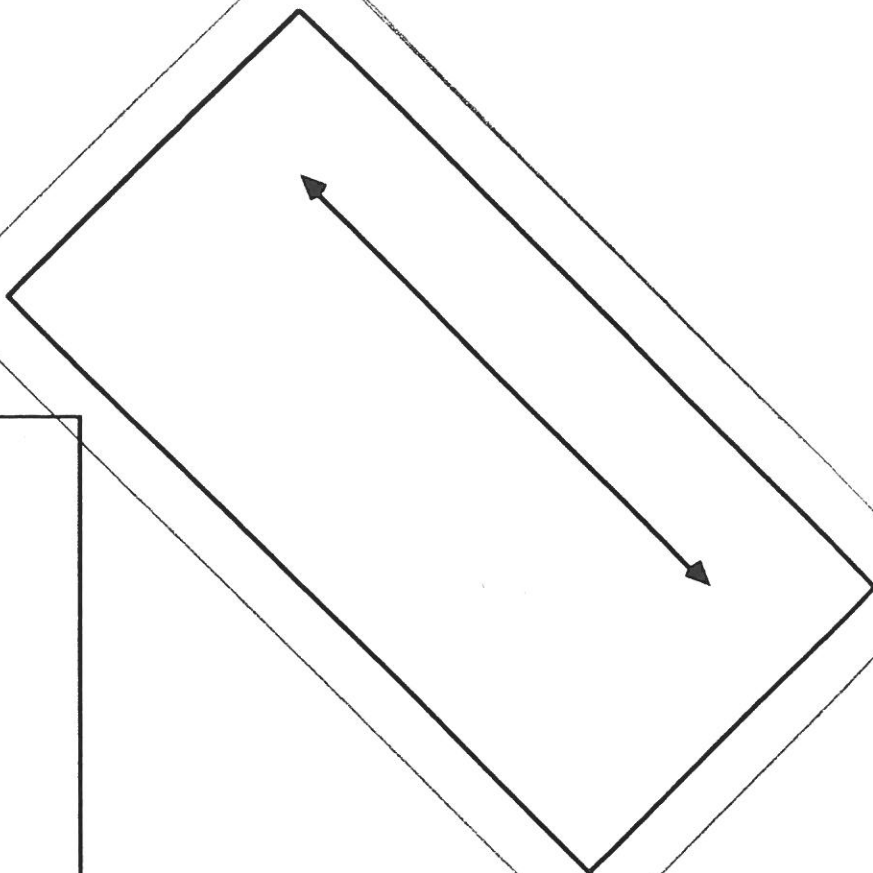

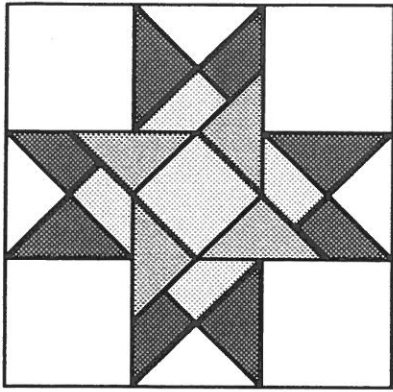

Heritage Quilters of Hunstville
Block of the Month
Black Forest Torte
(November)

must add seam
allowance on all
pattern pieces

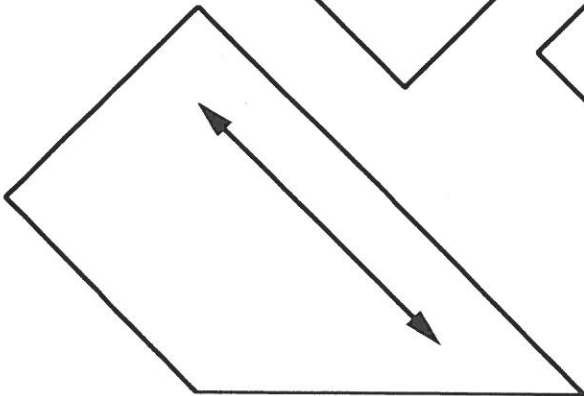
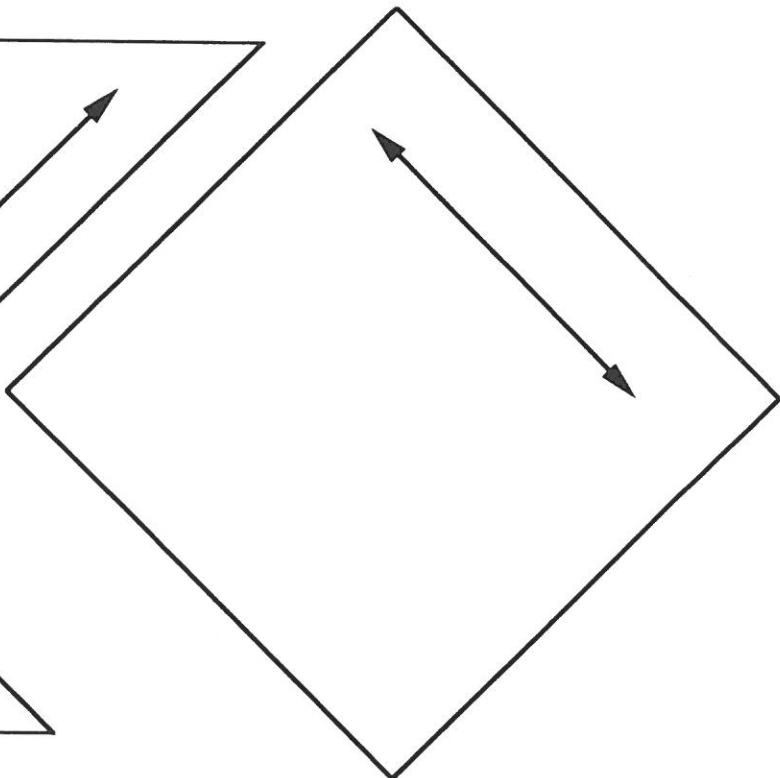
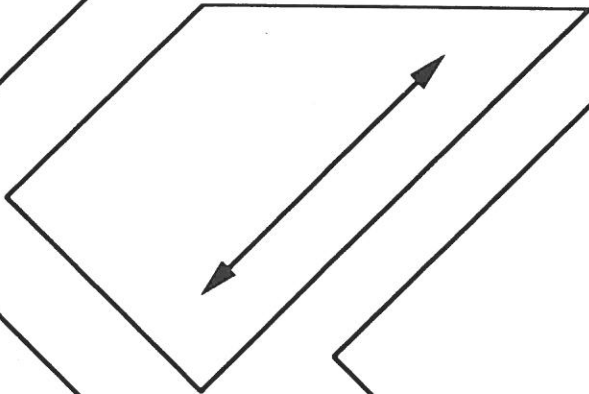
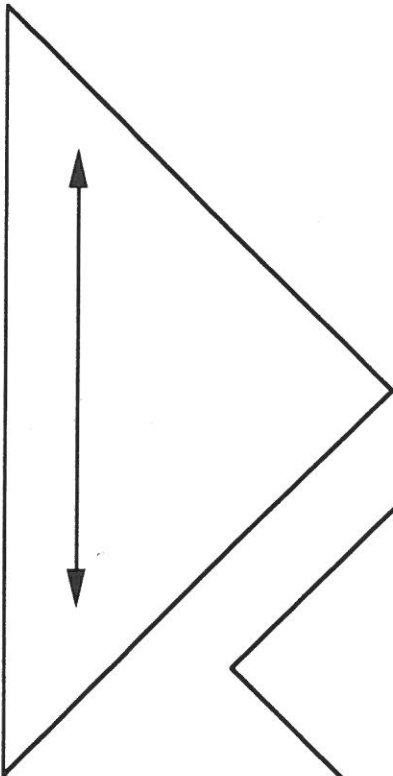
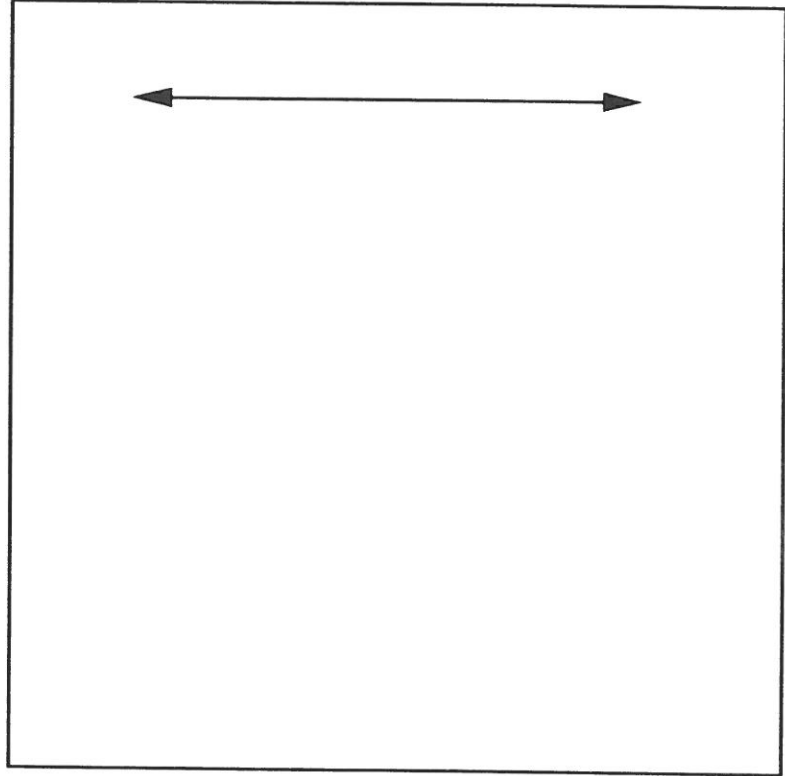

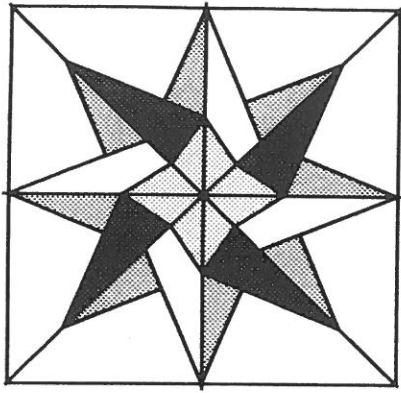

Heritage Quilters of Huntsville Block of the Month

(December)

Silent Night

must add seam
allowance on all
pattern pieces

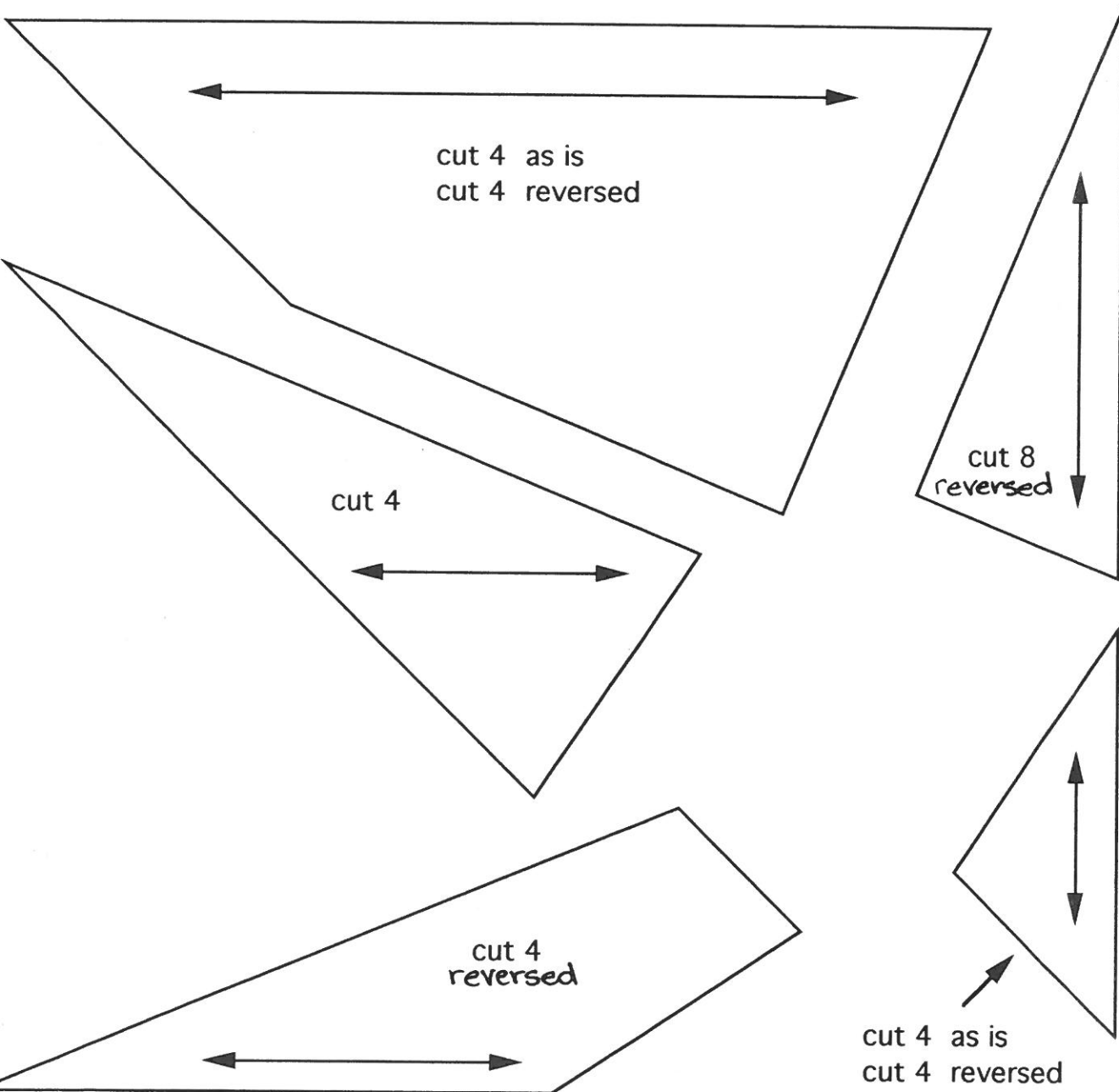

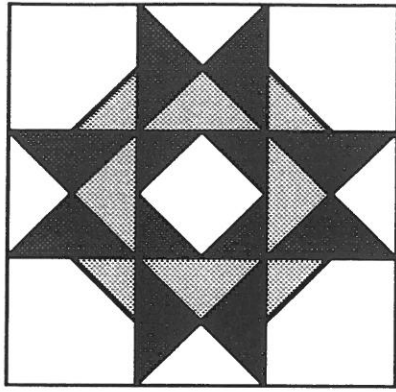

**Heritage Quilters of Huntsville
Block of the Month**

(January)

January Thaw

must add seam
allowance on all
pattern pieces

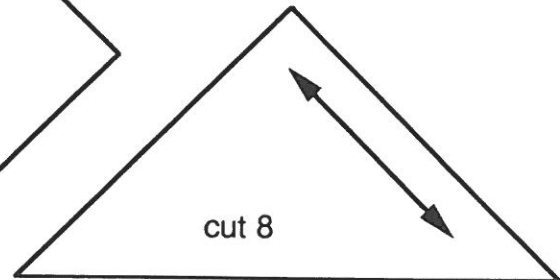
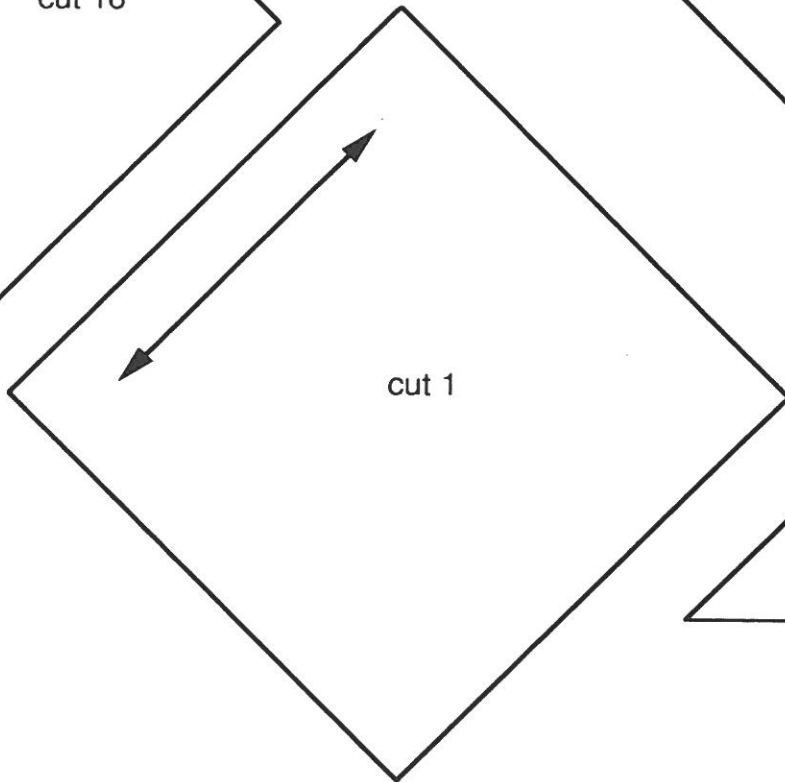
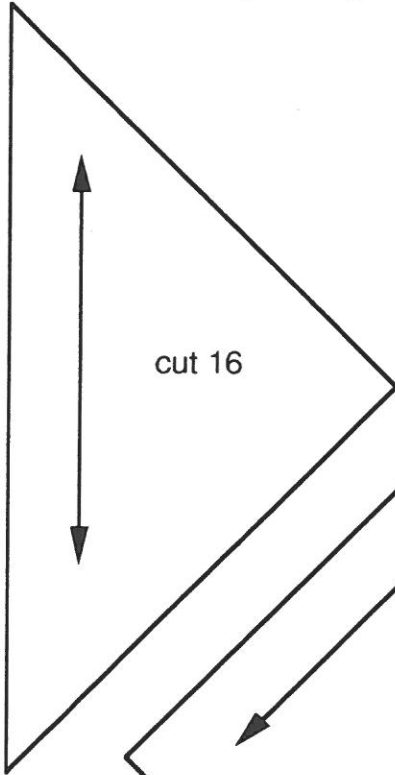
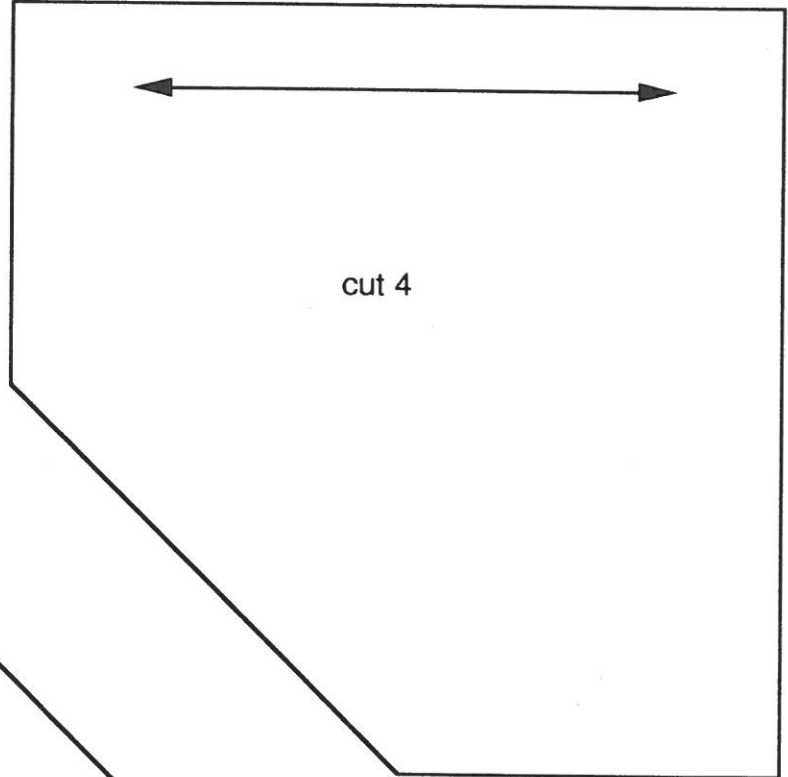

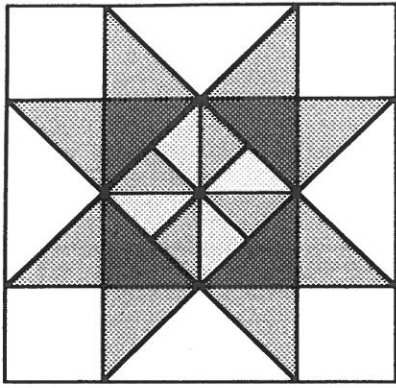

Heritage Quilters of Huntsville
Block of the Month
(February)
**Martha Washington
Star**

must add seam allowance on all pattern pieces

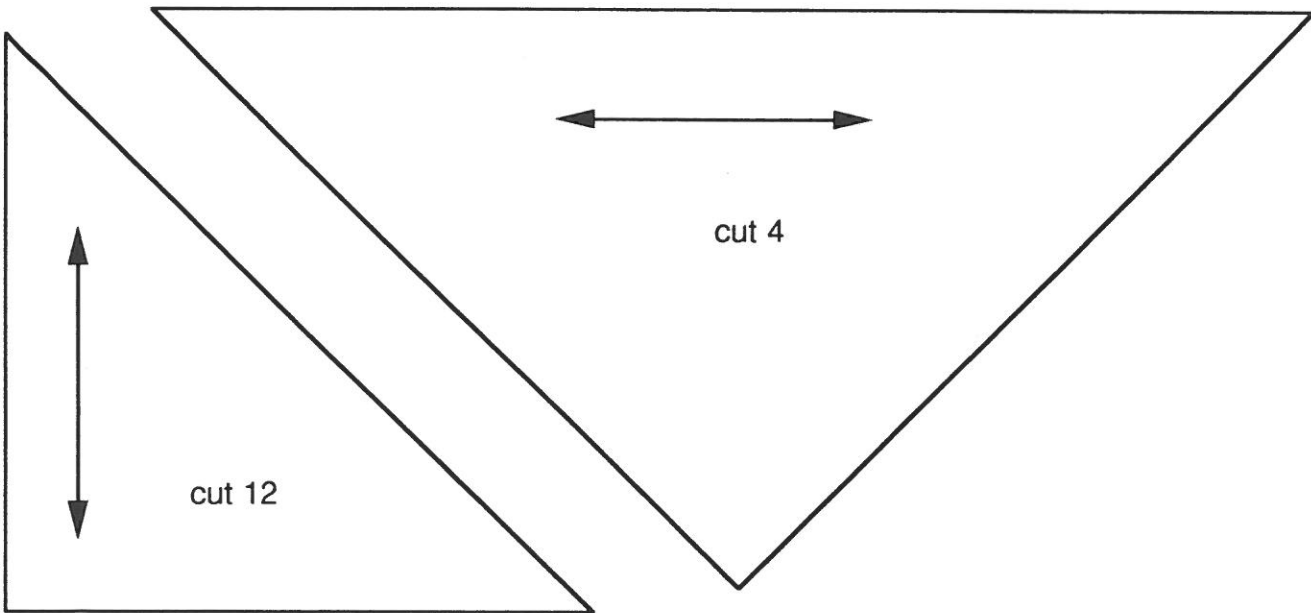
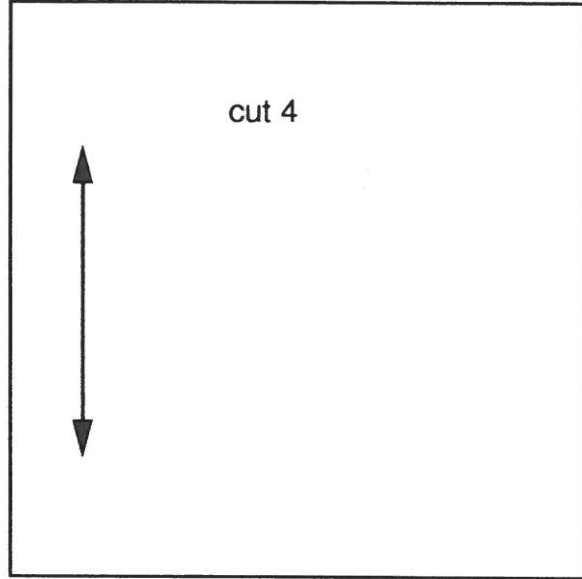
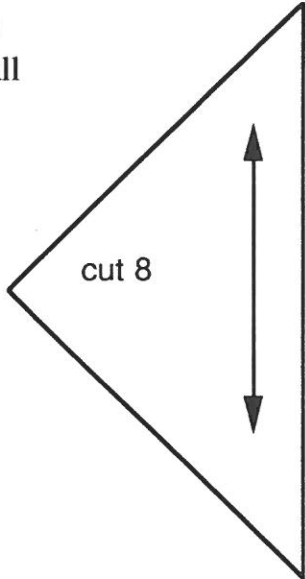

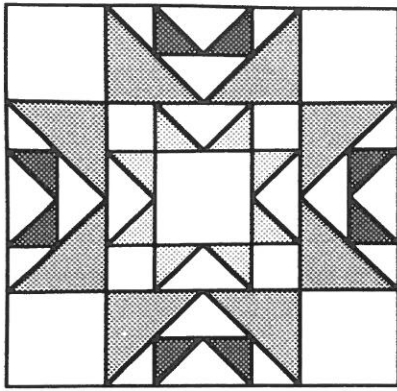

Heritage Quilters of Huntsville
Block of the Month
(March)

Colorado Star

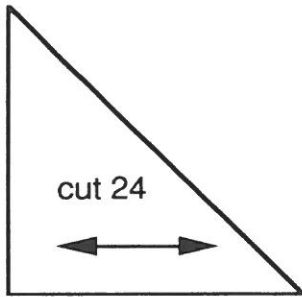

must add seam allowance on all pattern pieces

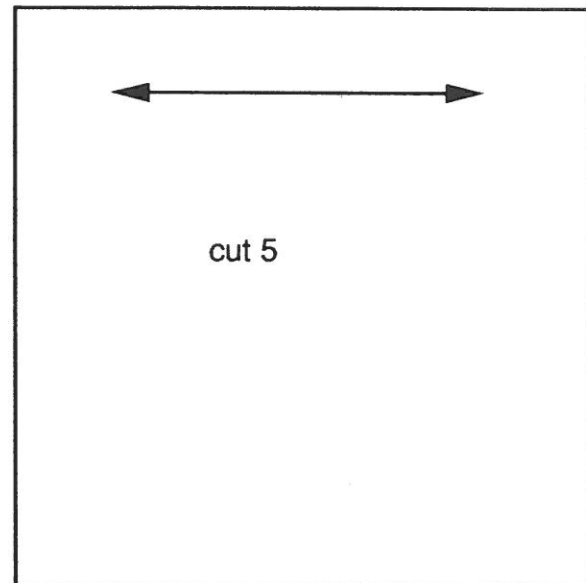
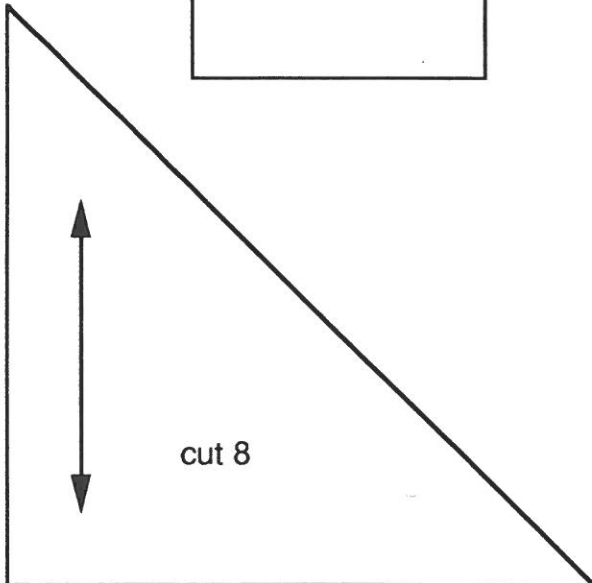
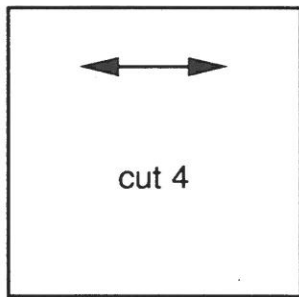
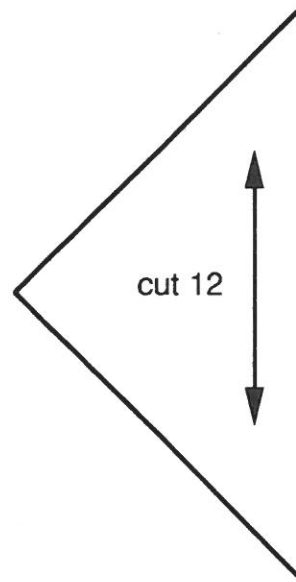

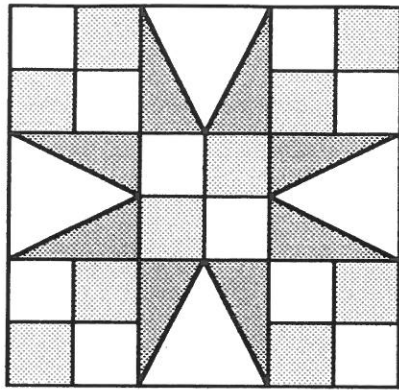

**Heritage Quilters of Huntsville
Block of the Month**

(April)

54-40 or Fight

must add seam
allowance on all
pattern pieces

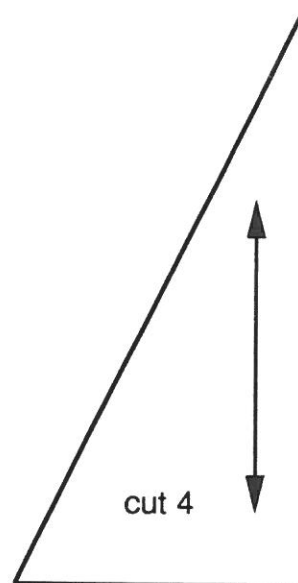
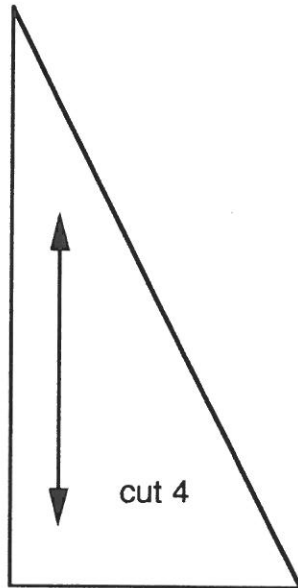
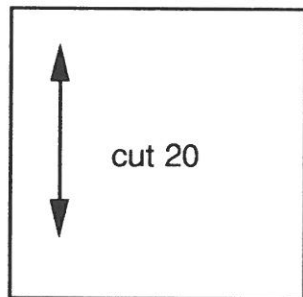
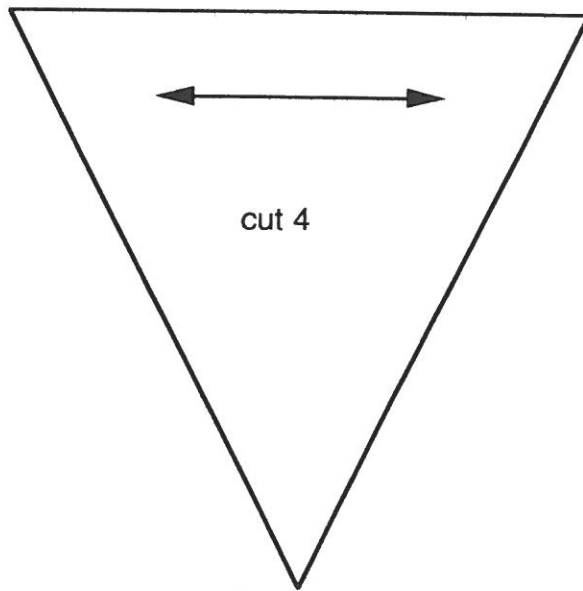

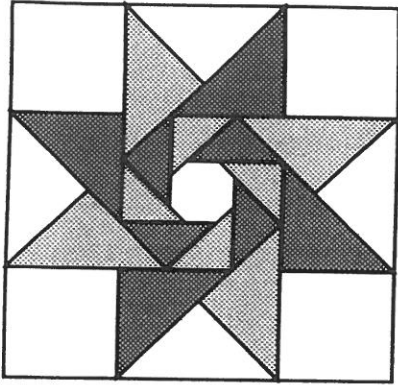

Heritage Quilters of Huntsville
Block of the Month
(May)
Star of the Orient

must add seam allowance on all pattern pieces

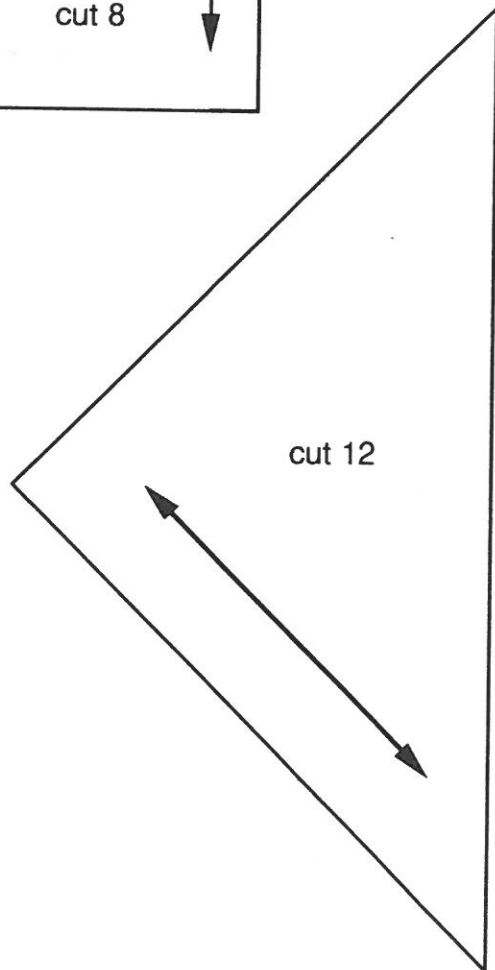
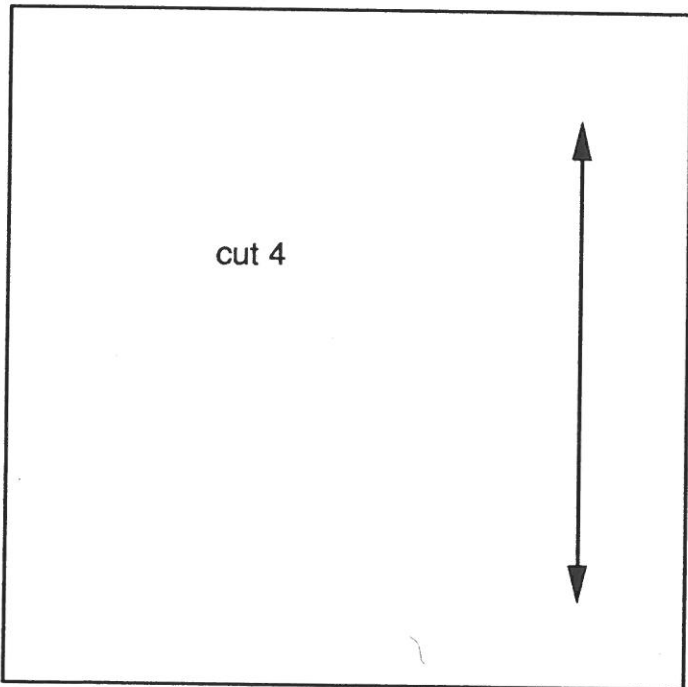
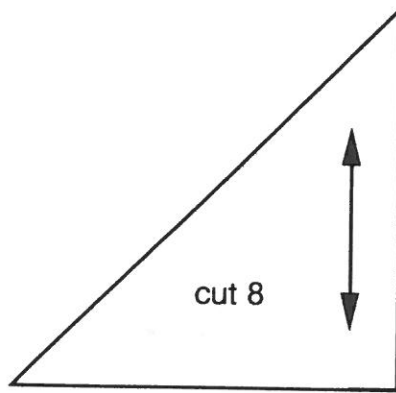
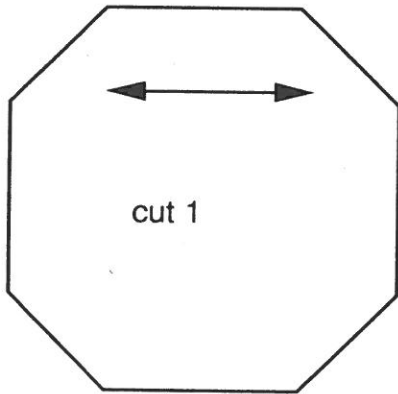

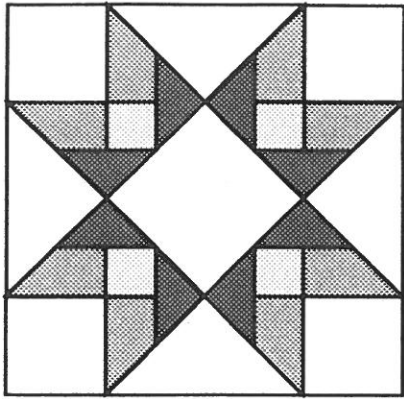

**Heritage Quilters of Huntsville
Block of the Month**

June Bride

must add seam
allowance on all
pattern pieces

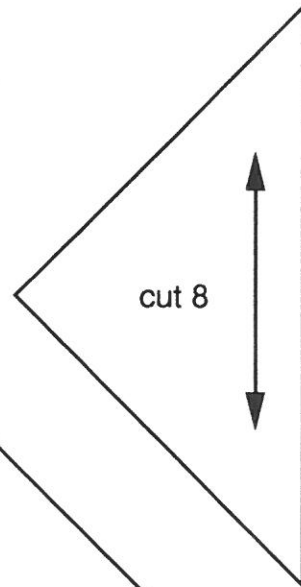
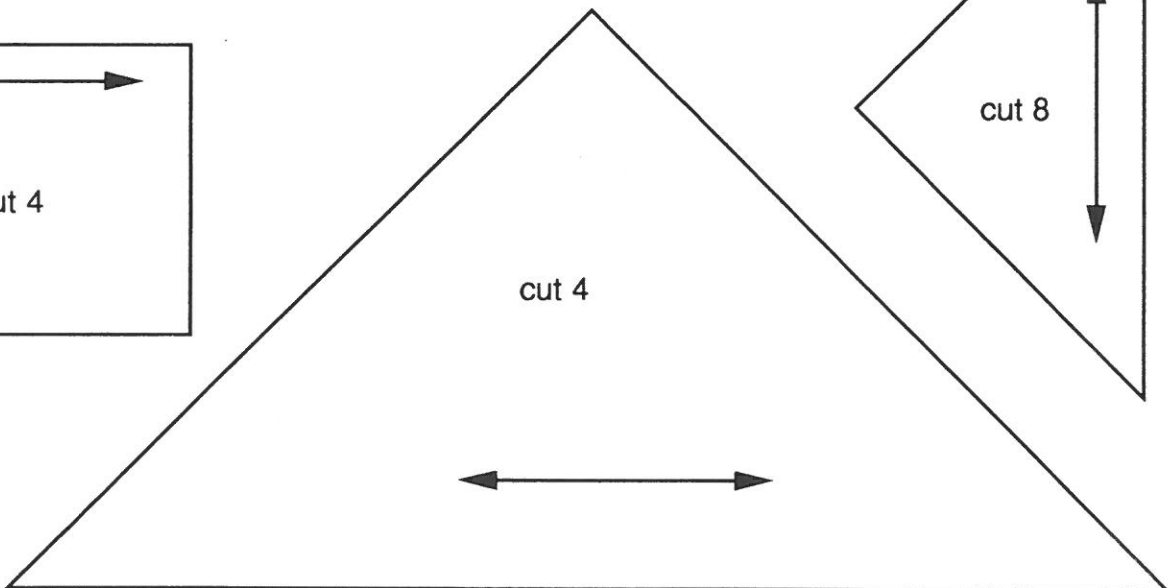
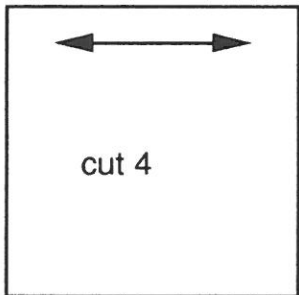
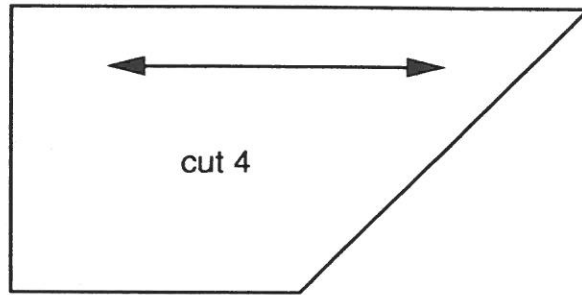
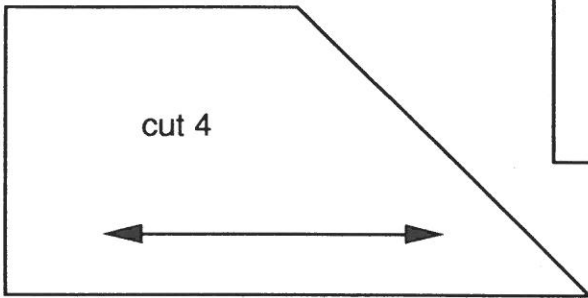

June Bride

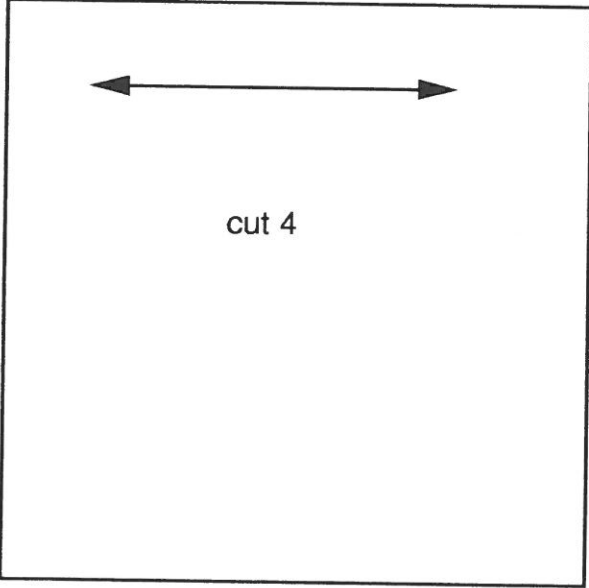
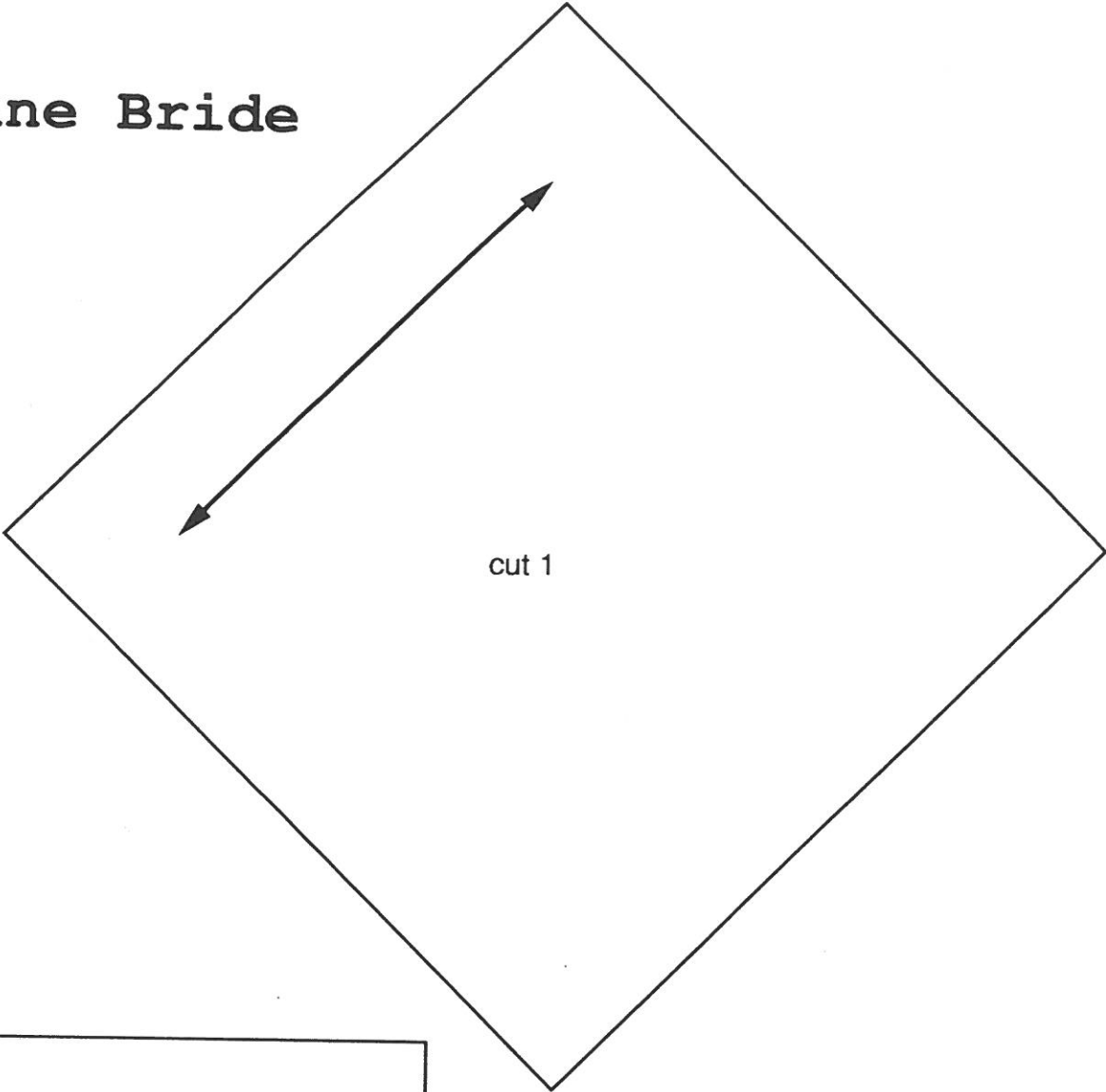

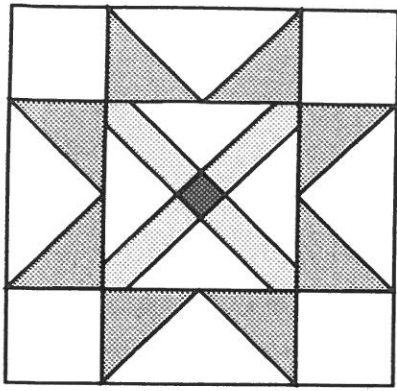

Heritage Quilters of Huntsville
Block of the Month
(July)

Independence Block

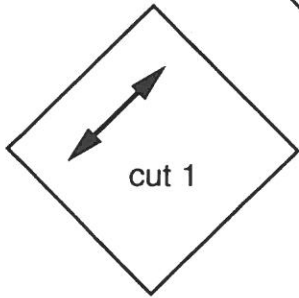
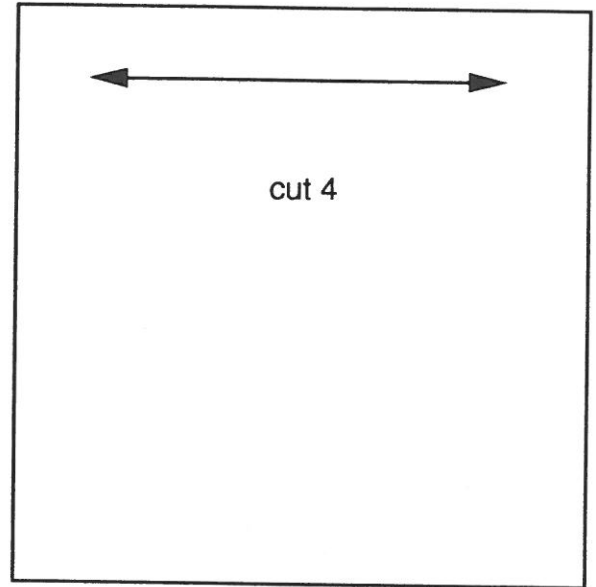
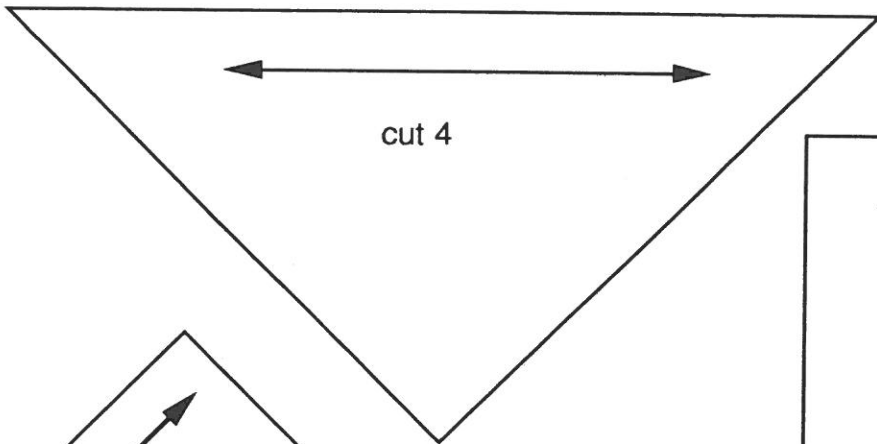

must add seam
allowance on all
pattern pieces

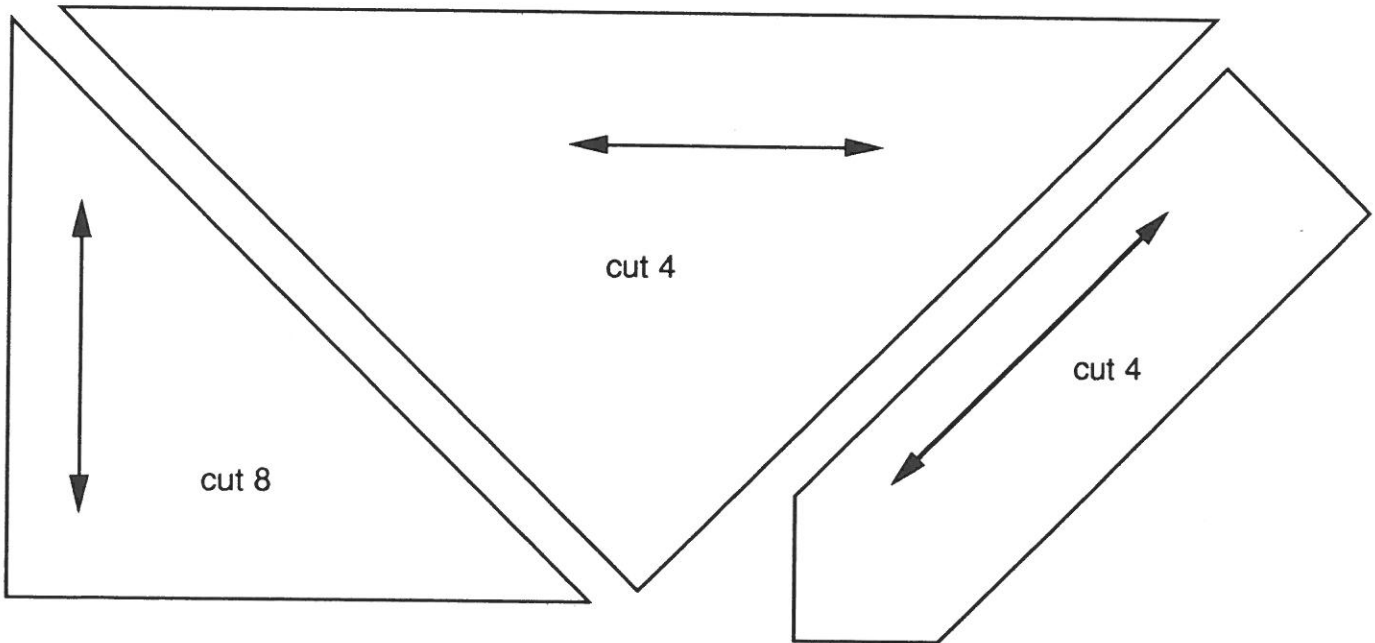

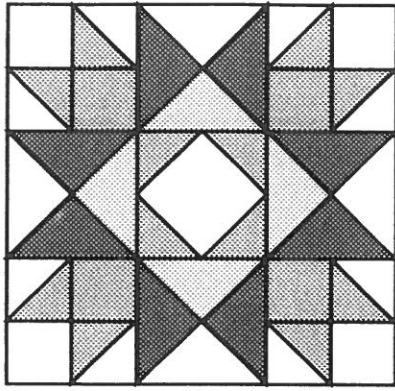

**Heritage Quilters of Huntsville
Block of the Month**

(August)

American Beauty

must add seam
allowance on all
pattern pieces

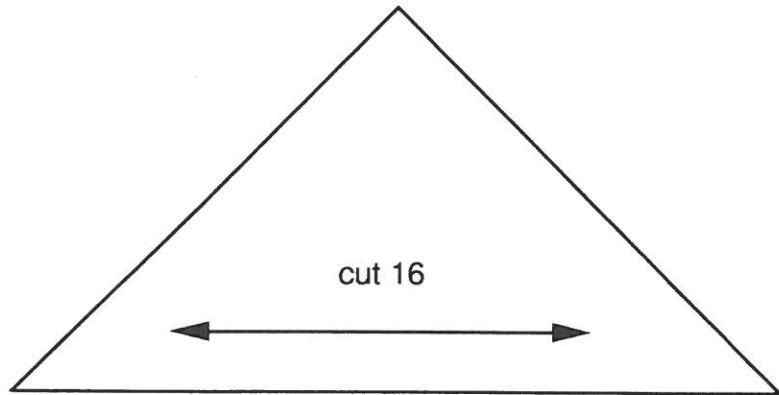
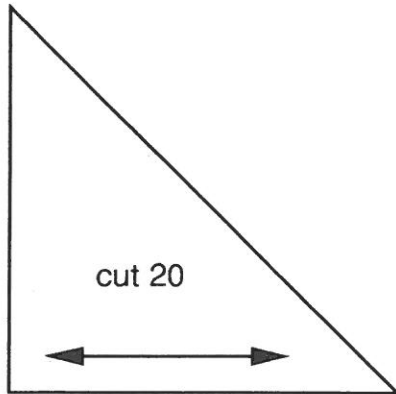
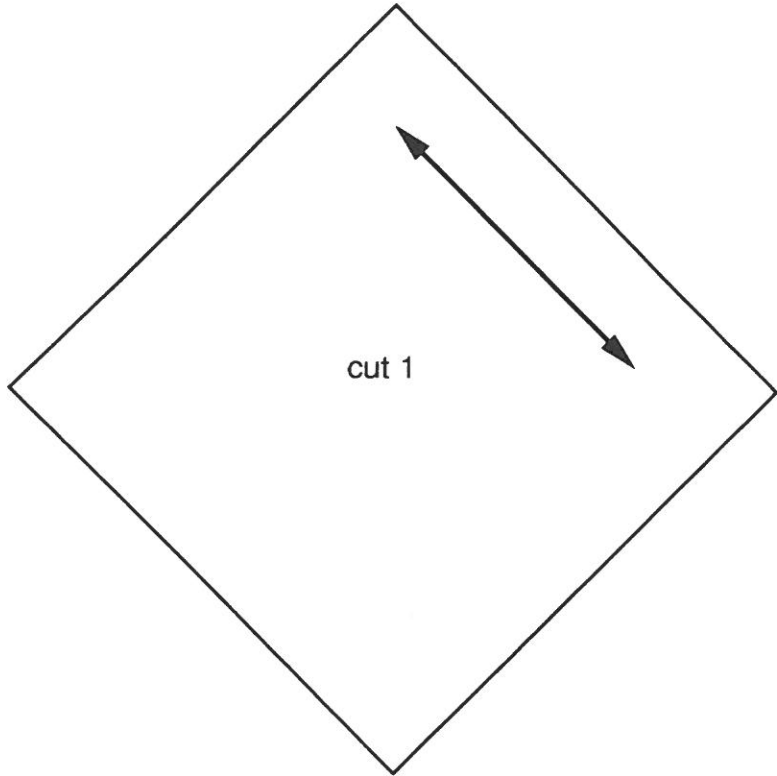
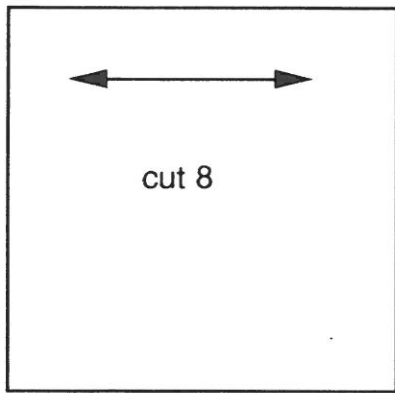

Heritage Quilters of Huntsville

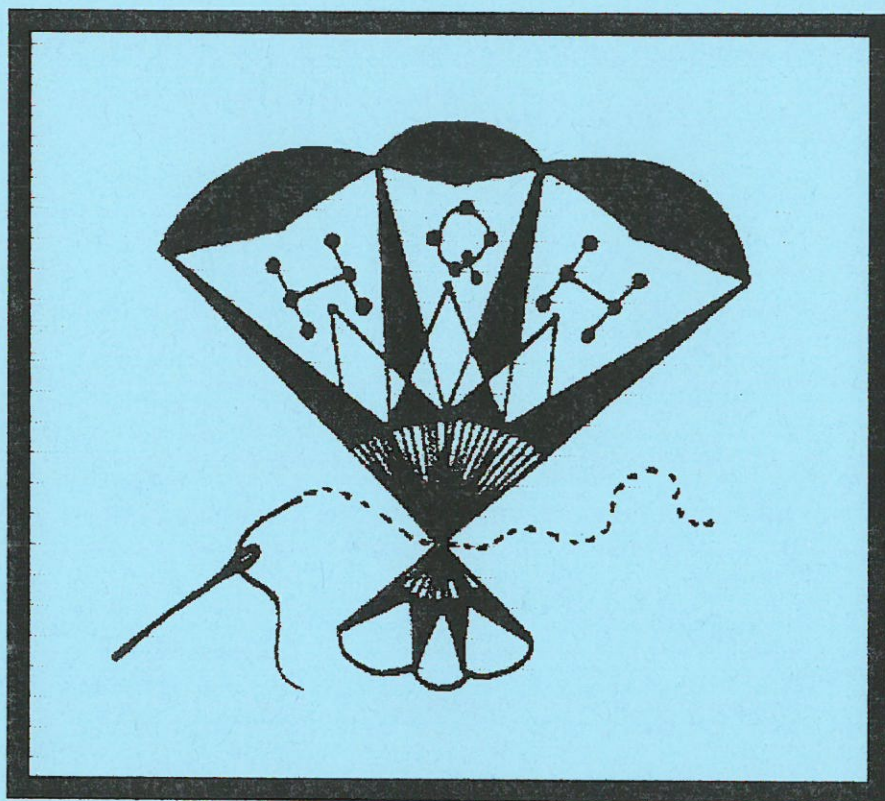

Series Quilt Patterns

1992/1993

**Tulip appliqué quilt
September 1992 thru August 1993
designed by Ellen Anson**

1992-93 Series Quilt

Designed by Ellen Anson

Yardage Requirements:

1 yd. Background fabric

1 1/2 yd. Border

3/4 Leaves & stems (Two 1/3 yd. pieces may be used for contrasting stems plus
an additional fat quarter for leaves)

2/3 yd. total for flowers and hearts (may use several fabrics)

1/2 yd. center triangles.

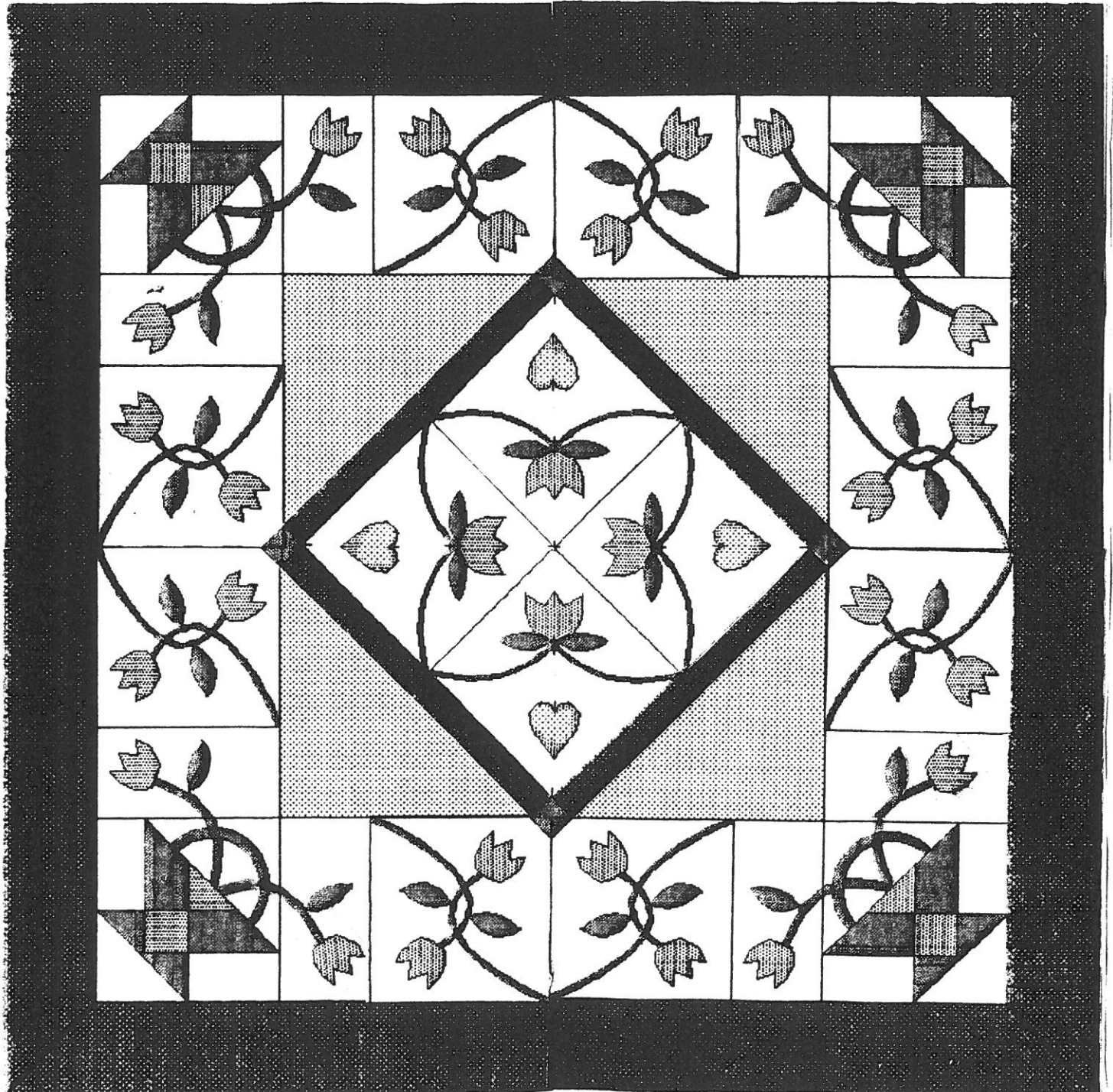

48 x 48

Applique Instructions:

Make plastic templates of flower, leaf and heart. Mark right side of template. Cut four squares of background fabric that are 8 1/2" square. Mark 1/4" seam allowances on all sides so that finished square will be 8". Place squares on top of placement pattern, matching all four seams on sides. Place plastic template, right side up, on background fabric, matching to placement pattern. Draw around each of the patterns with a very sharp, hard lead pencil. Do not mark lines for stem placement at this time. Using same plastic template, draw around template on right side of material to be applied on. Cut around pencil line leaving a scant 1/4" seam allowance. Clip only inside curves (see illustration).

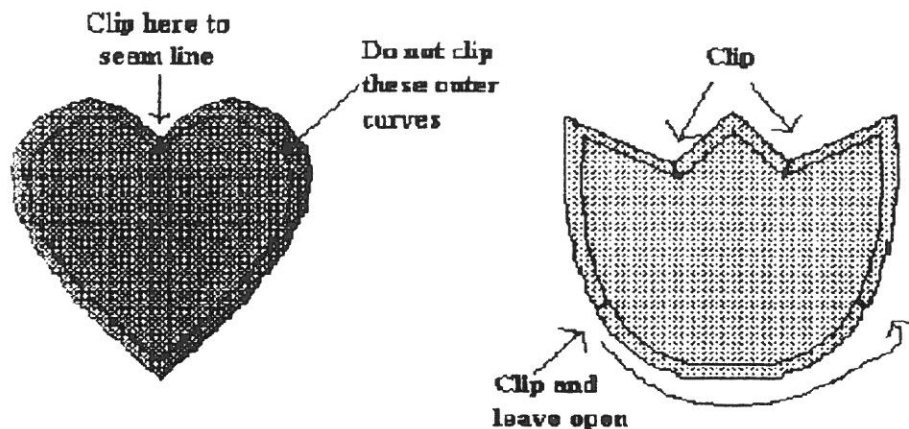

Lay piece to be applied on background fabric, matching pencil lines all the way around. Take a couple of basting stitches in this to hold in place. Fold under a little of the applique piece at a time as you are sewing, making sure that pencil lines are matching. Use thread to match color of piece being applied onto background. Applique heart and flower only on each square, clipping where indicated on placement and leaving bottom part of flower open. This is so that stem can be placed under flower at a later time. Leaves will not be applied this month.

Center Block Option:

You may not be interested in making the series quilt, but the center block has possibilities all of it's own! When several blocks are put together, the graphic below shows how they will look. What a cute idea for a baby quilt or a quaint little wall hanging.

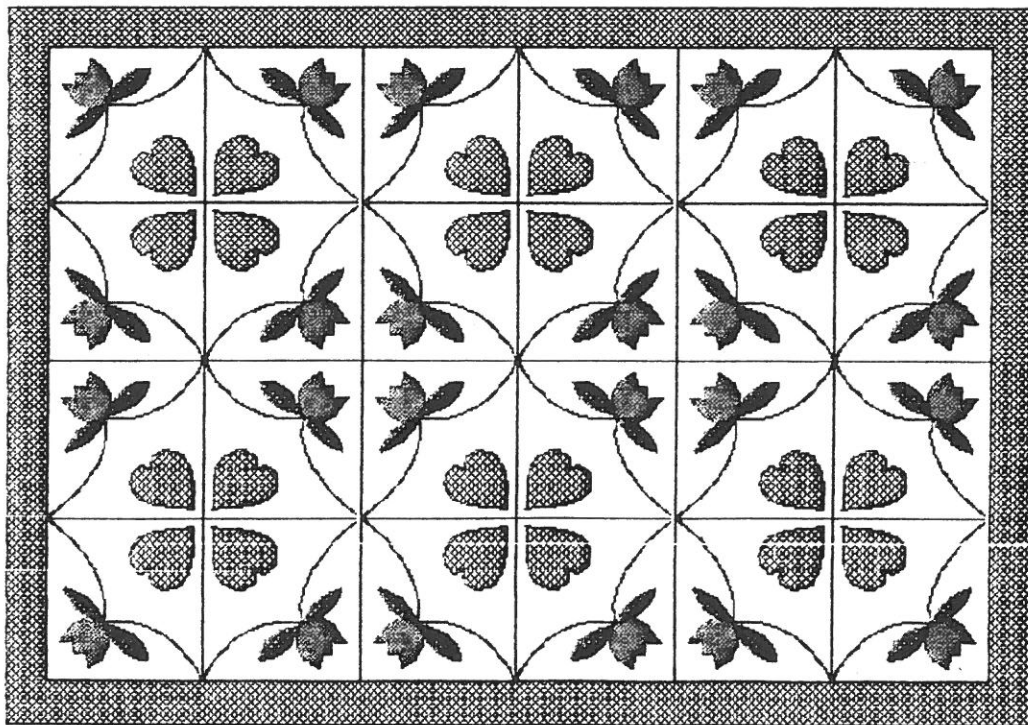

2

2

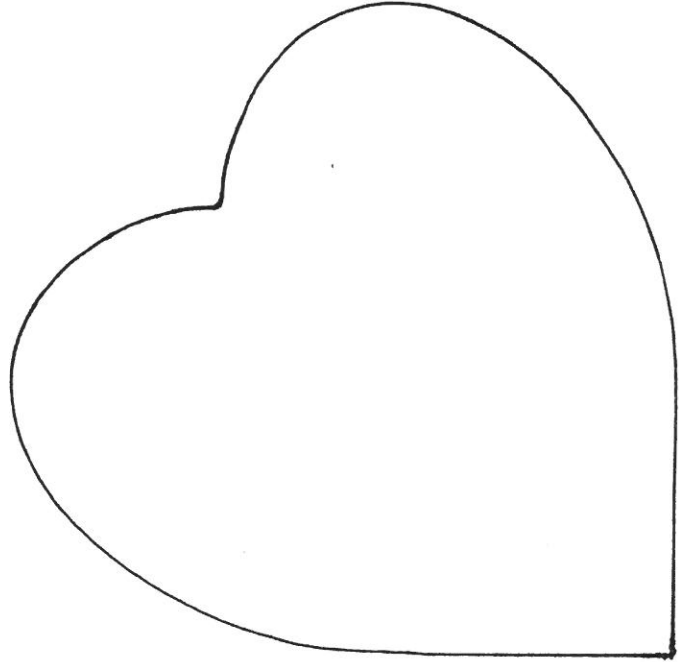
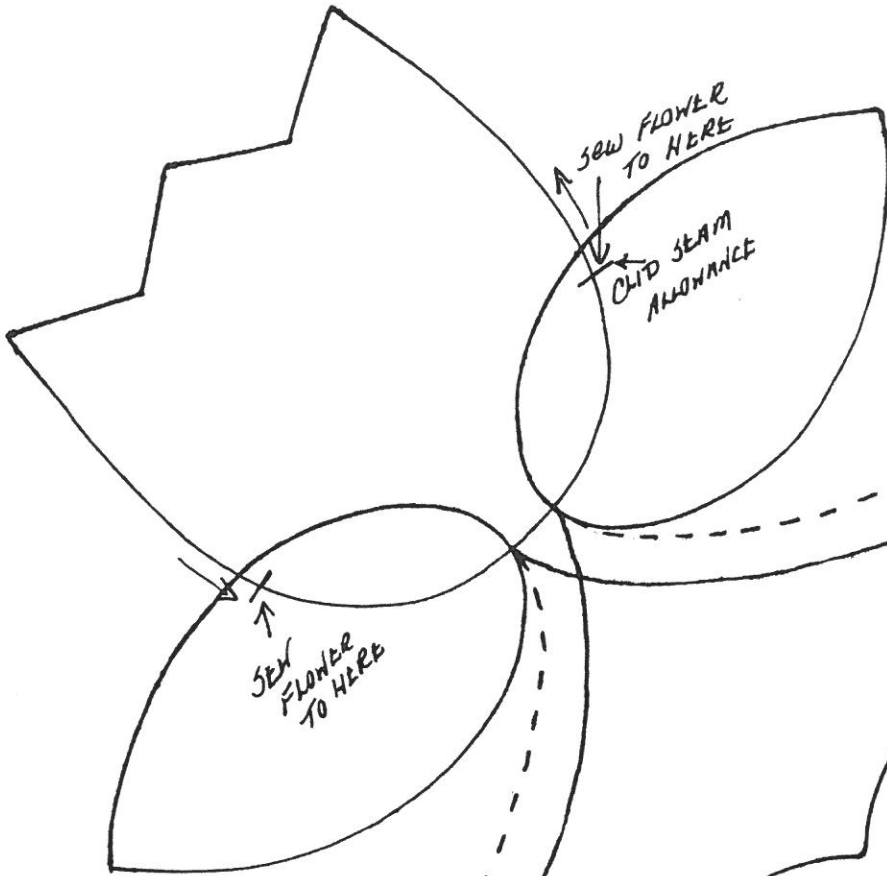

1992-93 Series Quilt - November

Making Bias Stems:

Cut 2 10 1/2" strips x 45" from the green stem fabric. Lay these two strips together. Use bias line on rotary cutter ruler to cut triangles off the end. (see illustration). Cut strips on bias that are 1 1/4" wide. You will need 24 of these. Leaves can be cut from remaining fabric.

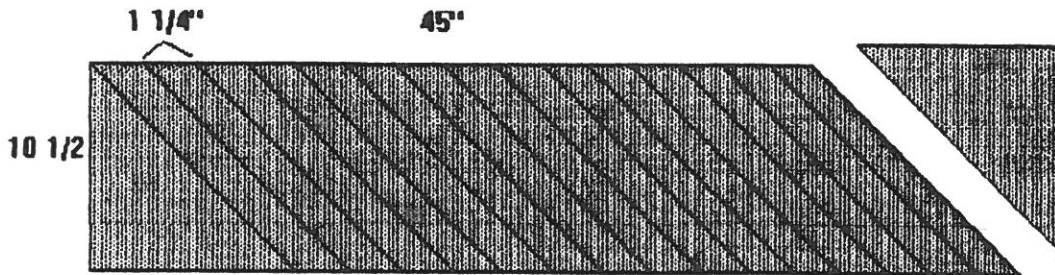

Fold each strip in half, wrong sides together, to make strips that are now 5/8 wide. Stitch 3/8" from the folded edge. (see illustration).

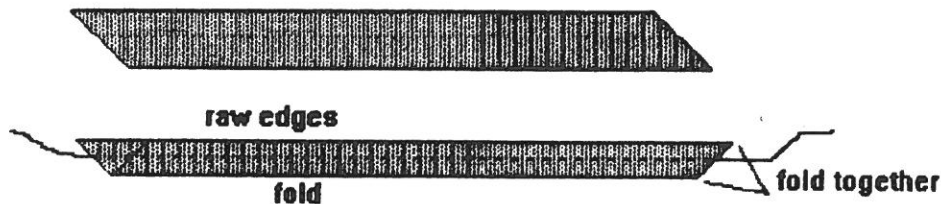

Fold again so that stitching line is just to the inside of the fold. Your stem should now be a generous 1/4". (see illustration).



Sewing Stems in Place:

Stem placement can now be marked on the center blocks that were appliqued last month. Mark solid line only - broken line is to indicate which side of solid line stem goes. I make a plastic template for the stem curve so that all stems are uniform, indicating the leaf position for proper placement. For the four center blocks, cut four of the bias stems that you have made in half, so that you now have eight shorter stems. The double folded side of the bias stem (the one with the stitching closest to it, and therefore the bulkiest) should go against the marked placement line. Applique stem on, making sure there is enough overlap to hide under the flower. Trim ends even with the block edge. Complete the flower. Mark leaf where it overlaps flower for proper positioning. Follow last month's instructions for applique of leaf.

1992-93 Series Quilt - December

Piecing Center Medallion:

Sew the four flower and heart squares together as shown on layout. For remainder of medallion you will need to cut:

- 4 Triangles that are $11 \frac{3}{4}$ " on right sides (straight on right sides)
- 4 Triangles that are $1 \frac{5}{8}$ " on right sides (straight on diagonal)
- 4 Strips that are $1 \frac{5}{8}$ " wide and $16 \frac{1}{2}$ " long

Sew two of the small triangles to each side of one of the long strips. Repeat so that you have two units that look like the illustration below.



Sew the two remaining strips to opposite sides of the center square. Add the two strips with triangles at each end to the remaining two sides. Sew the four large triangles to the four corners of center medallion.

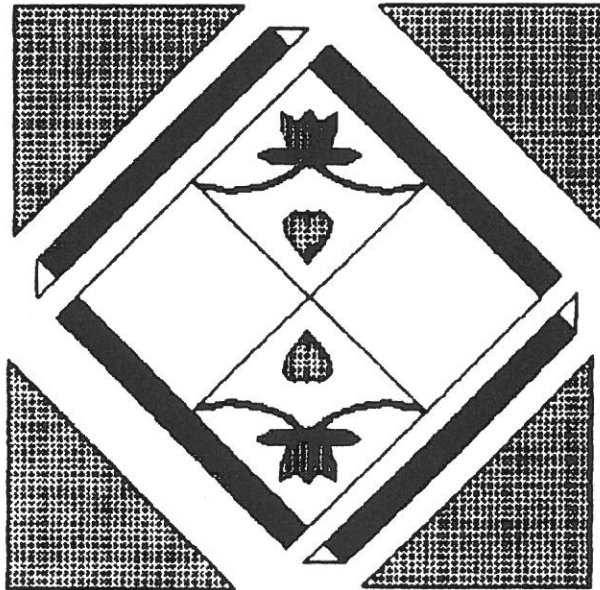

1992-93 Series Quilt - January

This month we will make the eight tulip blocks.

Cut eight squares of background fabric that are $8\frac{1}{2}$ " square. Mark $\frac{1}{4}$ " seam allowances on all sides so that finished square will be 8". Pattern needs to be reversed for half of these squares. This can be done by tracing the pattern given the back of the pattern. Place four of the blocks on the right side of the pattern and trace around pieces using method used in the October instructions. The other four squares can be traced from the back side of the pattern.

Tulip Block Option:

As with the center block, this block makes a nice design when repeated. For those of you not wishing to make the series quilt, you may try something like the quilts shown below.

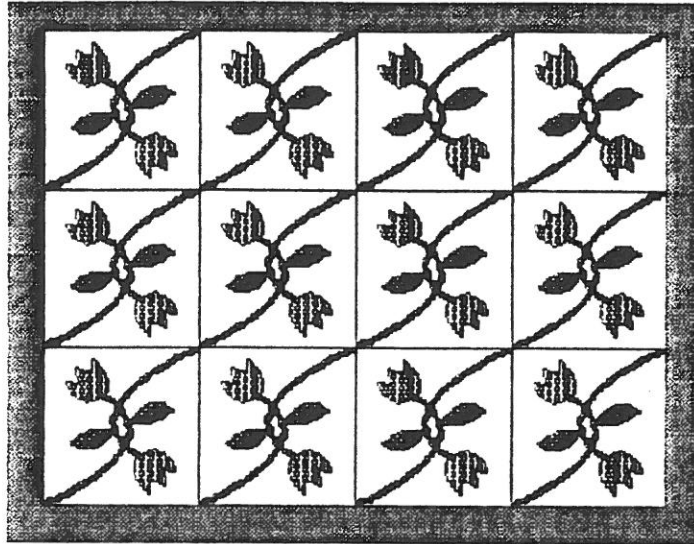

OR

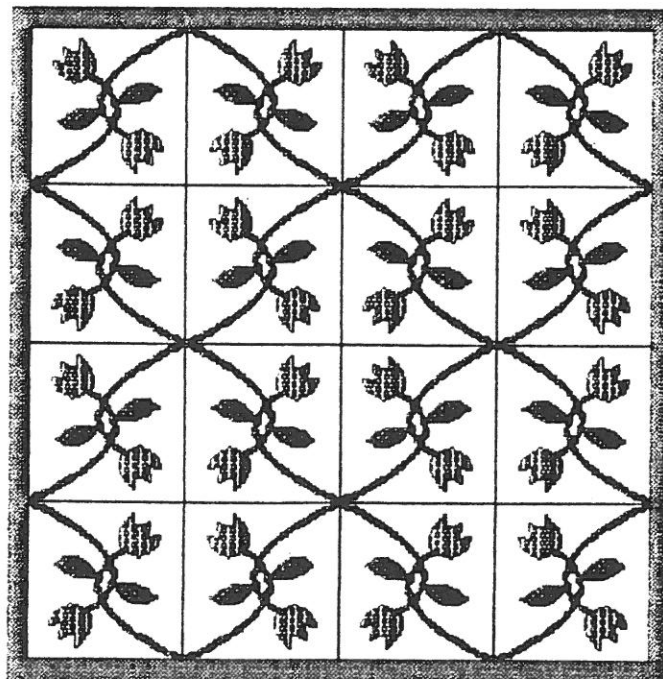

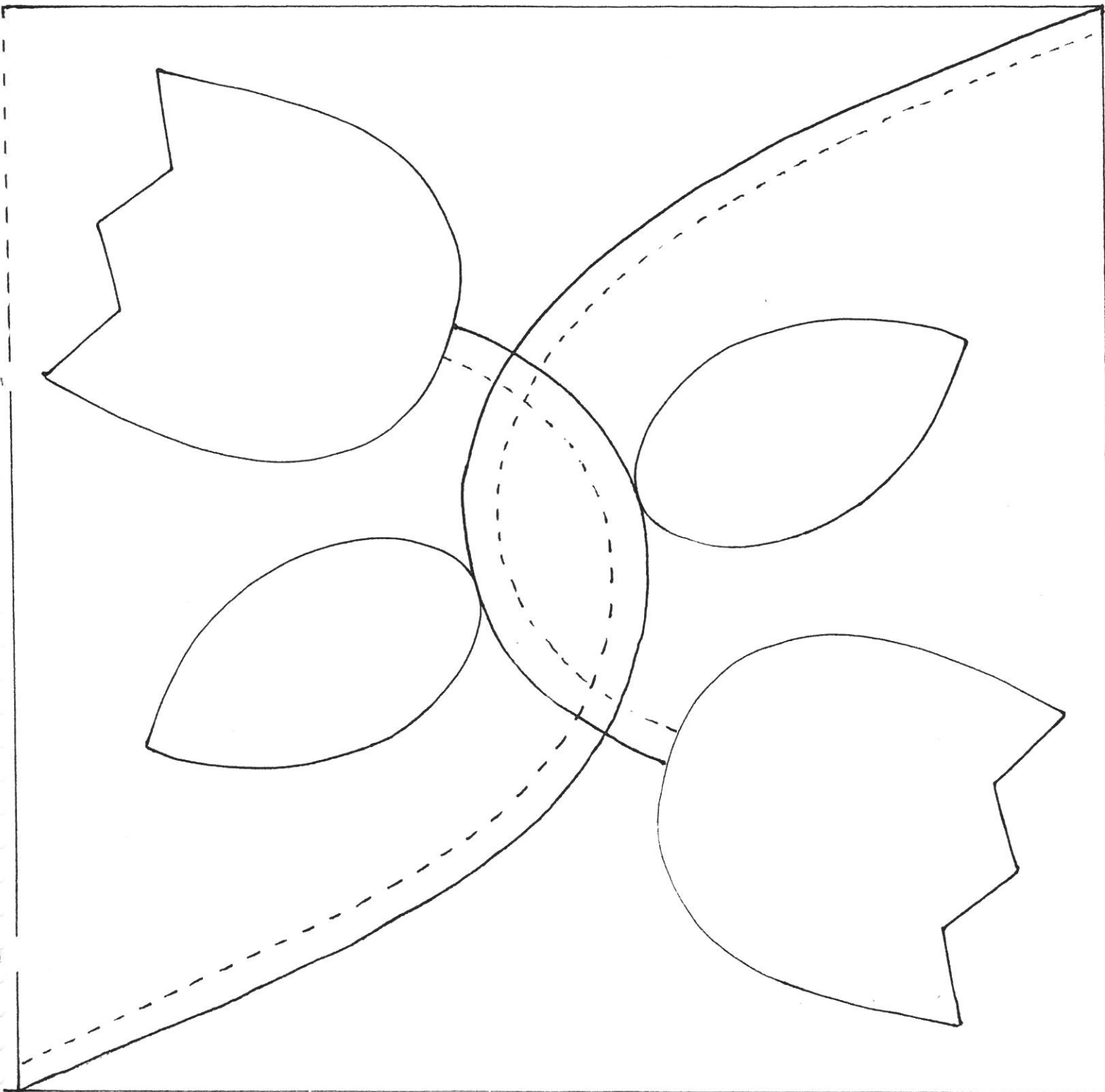

2

1992-93 Series Quilt - March

This month we will make the eight rectangular tulip blocks.

Cut eight rectangles of background fabric that are 8 1/2" x 4 1/2". Using the pattern below, trace placement for tulips, leaves, and stems. Pattern needs to be reversed for half of these blocks, following instructions given in the January directions. Applique only tulips and leaves at this time, leaving opening for the stem to be placed under the bottom of flower.

You should be getting good at tulips and leaves by now - if you are making the series quilt and have gotten behind, this a good month to catch up as there is not much to do!!

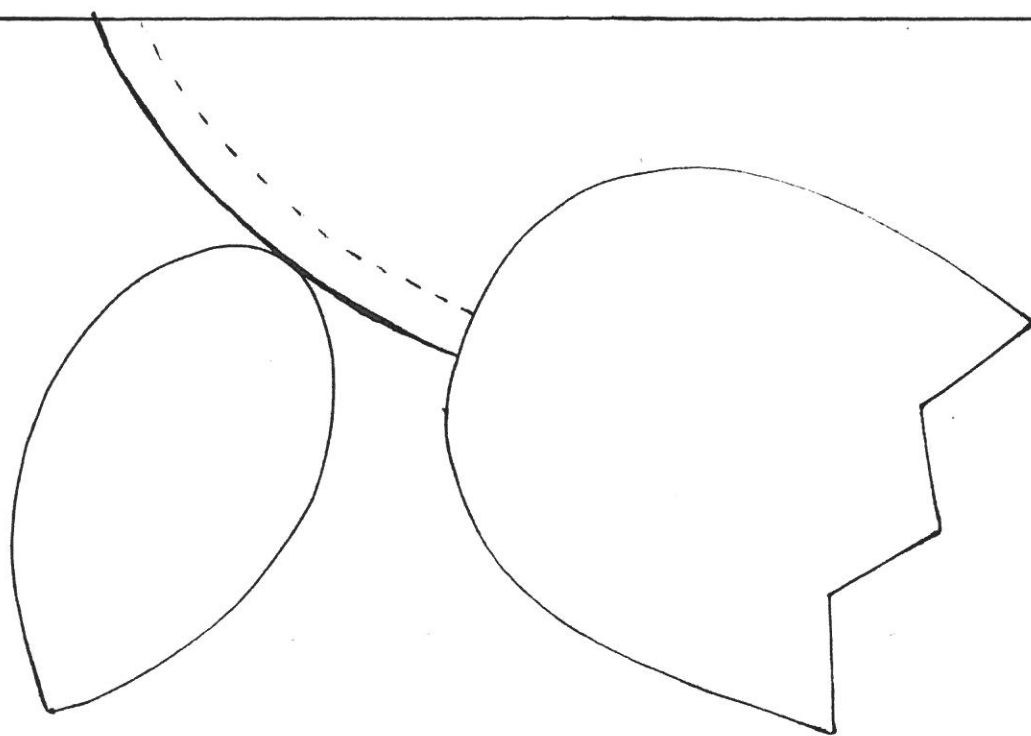

1992-93 Series Quilt - April

This month you will sew small triangles on the corners of the tulip squares, and sew squares together. Cut eight 1 1/4" squares of the same fabric used in the small triangles on the center medallion. Set these in the corners of the tulip blocks as shown below, right sides together and sew across the diagonal from point to point.

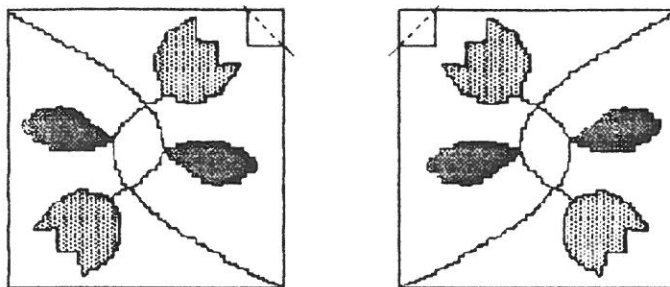

Press corners nearest the tulips up toward the outer point. You will have 3 layers of fabric on each corner. Trim the two underneath layers leaving the top triangle and 1/4" seam allowance.

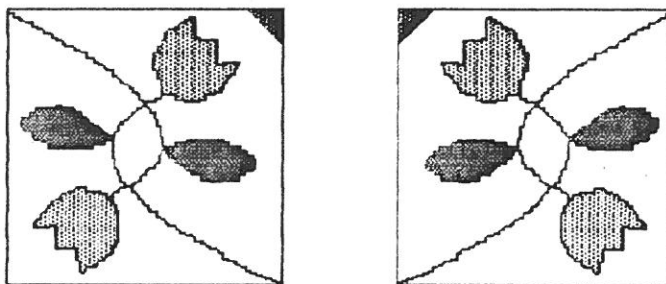

Sew the blocks in four sets of two as shown below:

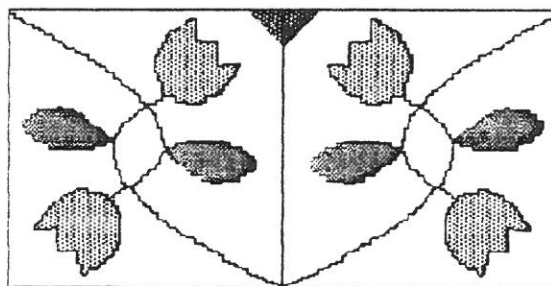

To give credit where credit is due, this method of easy "No Triangle Corners" can be found in a Quilt Lovers Series book called "Gathering Hearts #1" by Four Corners Publications. This method is used to make quick heart blocks and I used it here just to let you see how it is done. Check it out - there are many other possibilities for using this method to make perfect corner triangles.

1992-93 Series Quilt - May

This month we will put together the tulip and basket blocks and sew to center medallion. Sew together a combination of tulip blocks and baskets so that you have two strips each of those illustrated below:

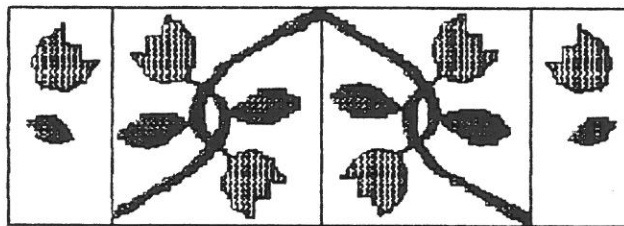
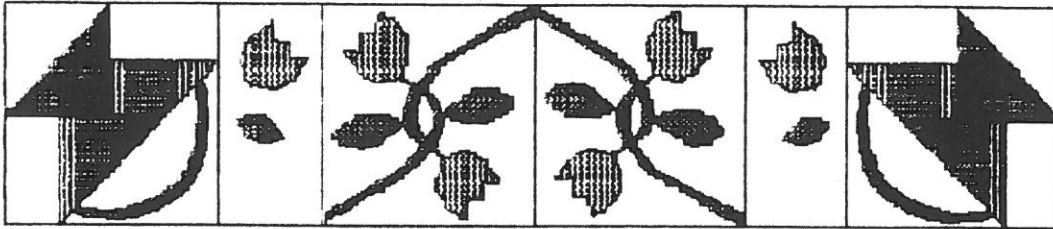

Sew the two strips without baskets to the sides of the medallion, making sure that corner triangles on tulip blocks and triangles in the center of the sides of the medallion match up.

Next sew the long strips with baskets on each end to the top and bottom. Make sure baskets are facing toward the center. If lines for stem placement from basket to rectangle tulip blocks do not match up, redraw them at this time.

1992-93 Series Quilt - June

This month you will sew the remaining stems from the center of the baskets, to the flower in the rectangle block.

You should now have eight remaining stems from those cut according to the November instructions. Place the ends of two stems in the opening left at the center of the basket. These should lay side by side as in the illustration below, not one on top of the other. Stitch across opening, embedding stem ends in seams.

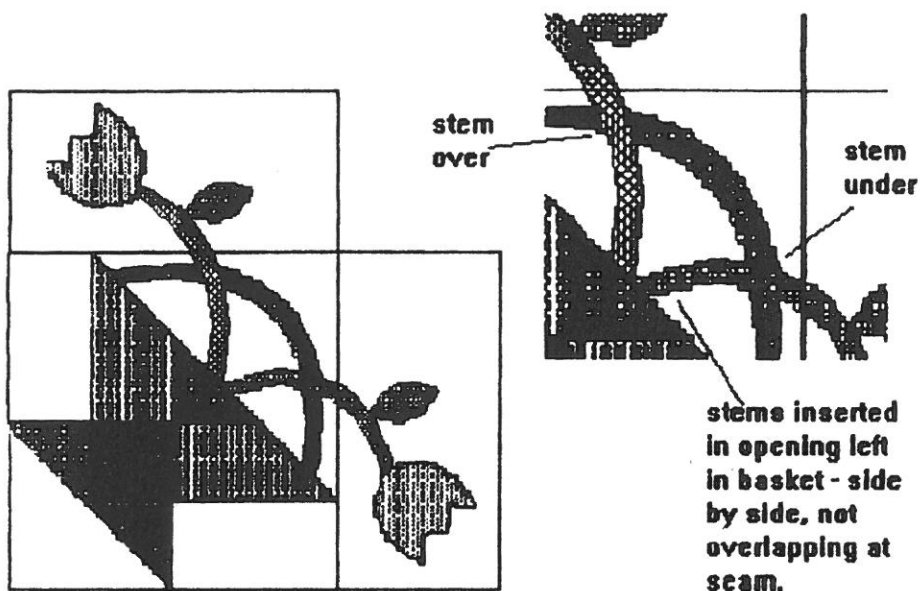

If you have left one side of the basket open where marked on the pattern given out in February, the stem on that side can be slipped under the opening and then again under the edge of the flower. The other stem may be appliqued over the basket handle and the end tucked under the remaining tulip. Be sure to applique the ends of the flowers and the basket handle in place.

1992-93 Series Quilt - July

This month you will sew the outside border in place - finally!!!

Cut four strips of fabric for the border that are $4\frac{1}{2}$ " wide and $48\frac{1}{2}$ " long. Mark these strips as shown below, indicating placement of blocks along the borders.

**CUT FOUR
MARK AS SHOWN;**

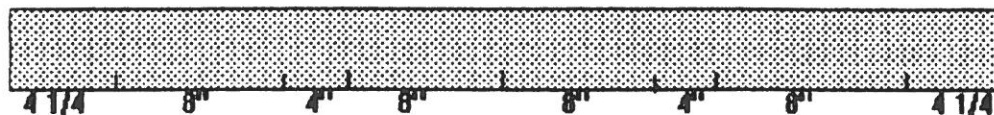

Sew borders to the four sides of the quilt, matching markings to blocks. The first and last markings should be at the seam allowance of the corner squares, with the outside $4\frac{1}{4}$ " of border hanging free. Backstitch at corners, making sure seam lines meet exactly.

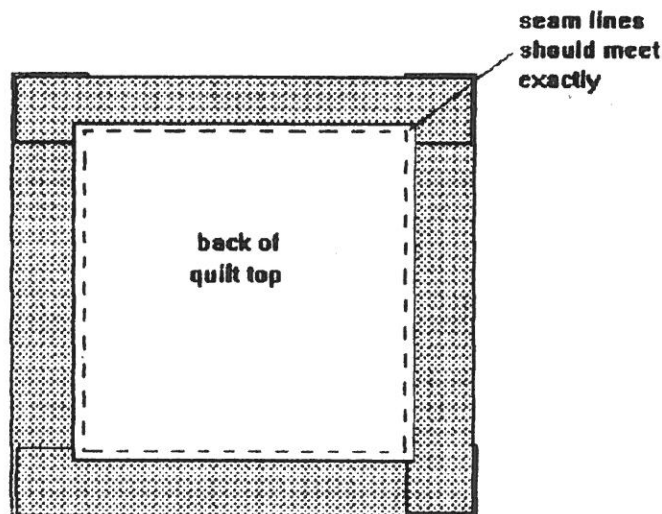

Fold two adjacent borders together along long sides, right sides together. Your quilt top will now be folded into a triangle. Turn seam allowances toward quilt top, away from border. Draw a diagonal from the point where the two seam lines meet to the outside corner of the two borders. Sew.

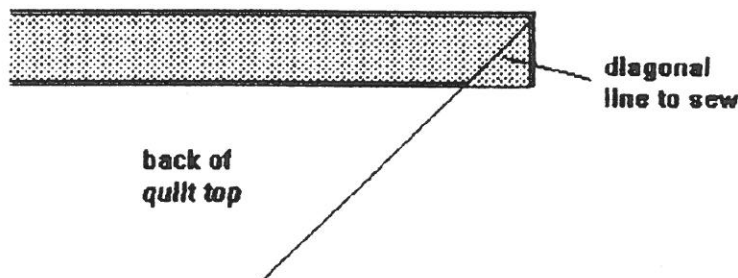

Open and press, pressing long seam toward border, mitre corner in either direction. Trim excess along diagonal seam to $\frac{1}{4}$ " seam allowance. Continue with other three sides.

1992-93 Series Quilt - August

Now that you have your wall hanging pieced together, you are ready to prepare it for quilting. This is a chance for you make it truly to your own liking by choosing your favorite quilting designs. Attached are a couple of suggestions for the four inch border and the large corner triangles, but feel free to put your own design in it if you prefer. Some suggestion for choosing quilting designs:

Make sure designs are balanced, that they look as though they are meant to be in that space.

All areas of the quilt should have about the same amount of quilting. An area that is less quilted than the rest of the quilt will not lay flat even though it did before it was quilted.

Anything that is quilted on will look flatter than something not quilted. Background diagonals or cross-hatching will help your fancy quilted or appliqued pieces stand out.

Test your marking implement for ease of removing it when quilting is done before you mark the entire top. If using pencil, take a sample piece and mark lightly, then quilt over it to see if pencil markings are light enough to be hidden by quilting.

When using a blue, water soluble pen, I spray the quilted areas with water as I complete a section and immediately place a towel on top of the wet area to draw up the water. This prevents the blue markings from coming back or spreading to other areas of the top or through the batting and backing.

Where to quilt:

Quilt on background right next to all applique pieces to give them depth. Quilt petals in flowers and veins in leaves as per the quilting design on following page. Cross hatch or diagonal the center medallion and flower applique blocks in background. If your corner triangles are a solid or print that will show up the center design on next page, use it. If the corner triangles are a large print or very busy, it may be better to continue diagonals or cross hatch in this or use an over design such as a clamshell. Stitch the basket 1/4" inside each piece and on the background next to handle.

Marking cross-hatching and diagonals:

Decide how far apart your lines will be - remember, you can always add more quilting later. I usually start with 1" increments. With a ruler, mark every inch with a dot down the straight sides of each block. Connect these dots diagonally across the block. If cross hatching, continue the same thing going across the opposite diagonal. As indicated in the diagram below, these lines will be less than 1" apart along the parallel lines, therefore, the one inch markings on your see-thru ruler will not match up to them as you are drawing them. This is why it is important to mark the increments along the sides and connect the dots.

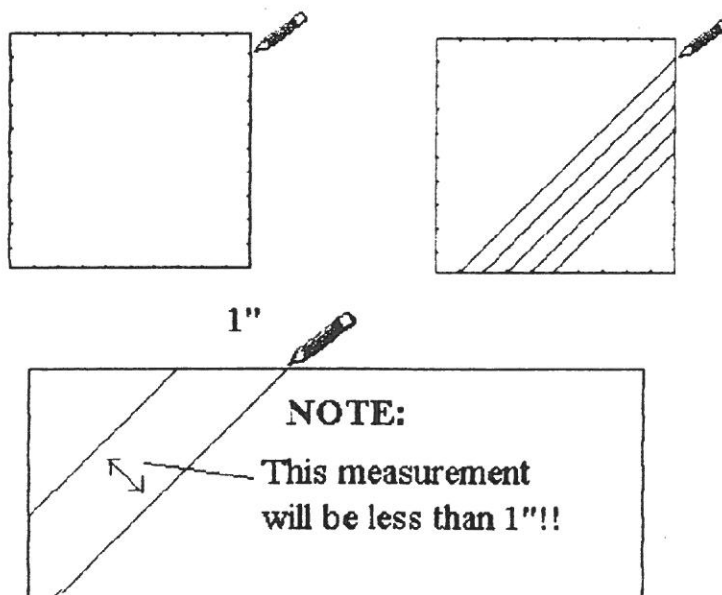

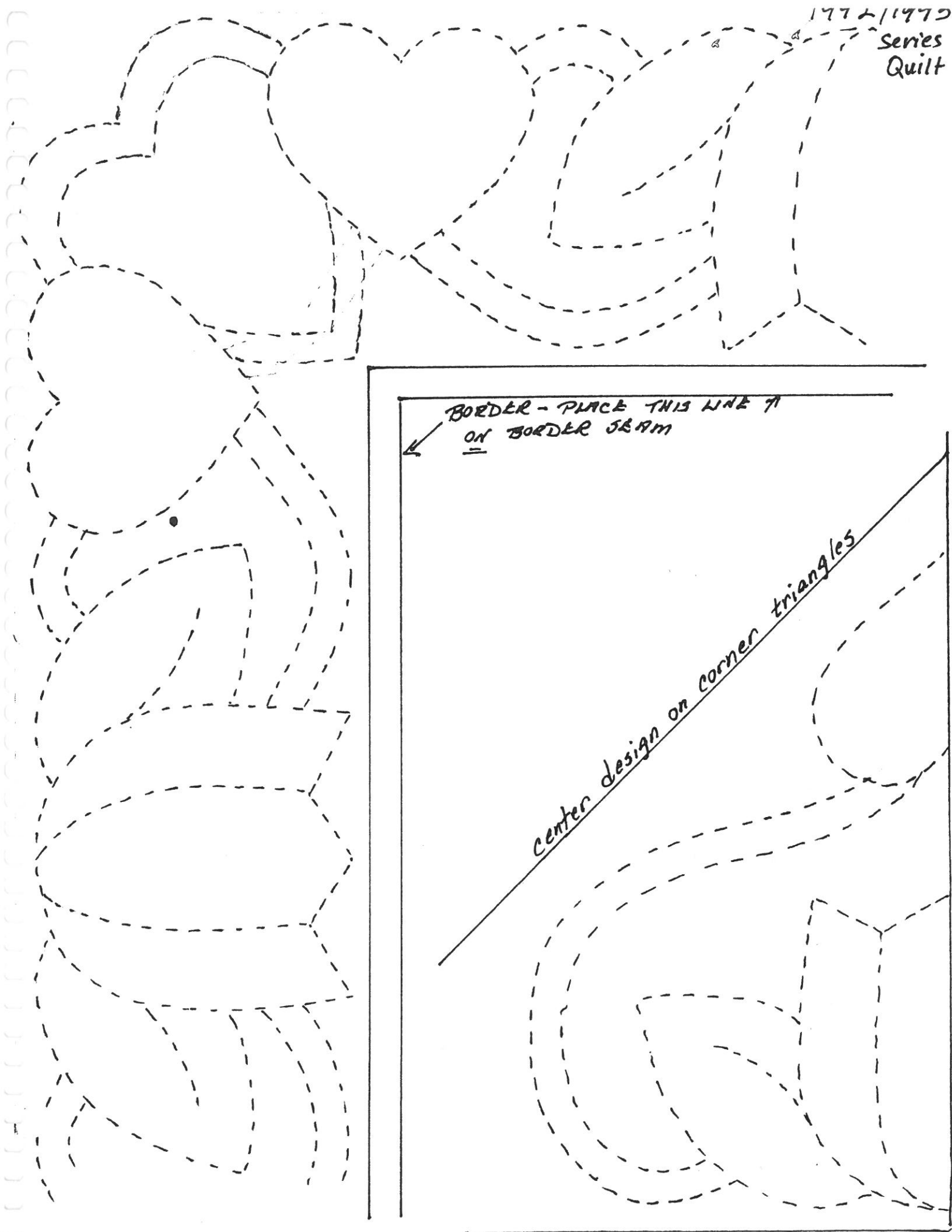

BORDER - PLACE THIS LINE IN
ON BORDER SEAM

center design on corner triangles

Heritage Quilters of Huntsville

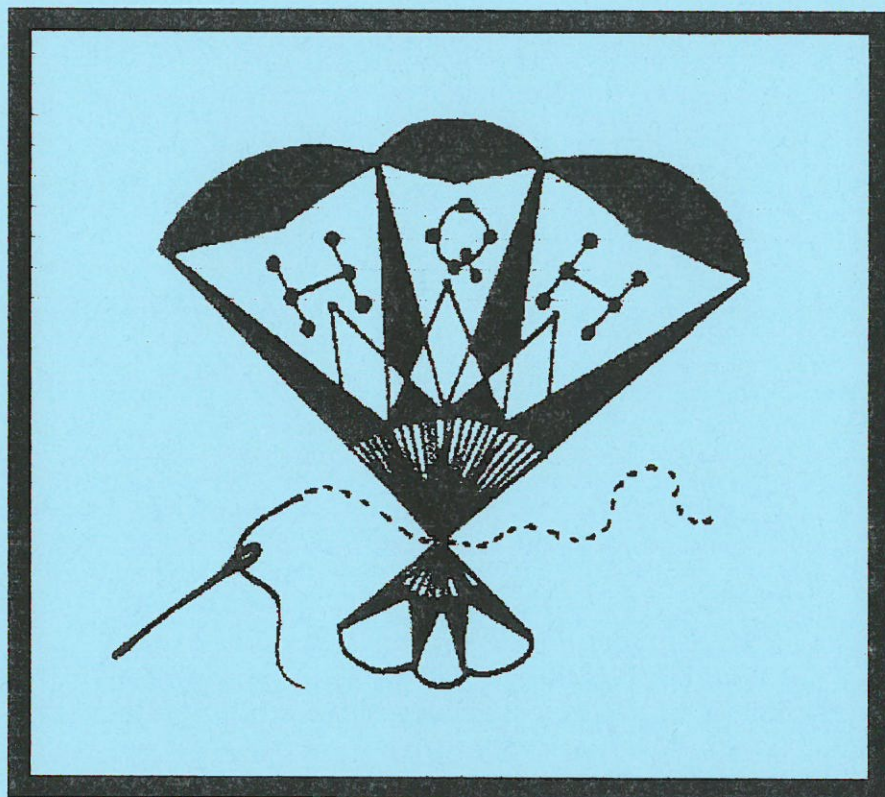

Mystery Quilt Patterns

1993/1994

**“Mystery! A Scrappy Surprise”
September 1993 thru February 1994
designed by Judy Hopkins
and Barbara Black**

MYSTERY! A SCRAPPY SURPRISE

(Barbara Black)

Part 1 of 6

written by Judy Hopkins and reproduced with permission of the author.

Do you love a good mystery? Try your hand at our new series where cutting and construction directions are divided into several distinct and "mysterious" steps, and nobody knows what they are making until they are finished! We will provide a bit of instruction each month, through the newsletter, and will demonstrate at the meeting the steps described that month. Embark on your mysterious quilt journey by selecting fabric and following the cutting instructions given below. You will eventually assemble the pieces you make into a scrappy, nap-sized quilt, about 60 x 76 inches.

A SCRAPPY SURPRISE--FABRIC

1/4 yard EACH of 10 different LIGHT prints (NOT FAT QUARTERS)
1/4 yard EACH of 6 different MEDIUM prints (NOT FAT QUARTERS)
1/4 yard EACH of 4 different DARK prints (NOT FAT QUARTERS)

Fabric requirements given are for blocks only; backing and binding fabric can be selected later. Use your own scraps or trade with others. Use more--or fewer--fabrics is your wish.

Your LIGHT prints can range from light to light-medium, your MEDIUM prints from medium to darkmedium. The fabrics in each value group can be all the same color (for instance, 10 different ivory prints for the LIGHT)--OR all the same value, but different colors (for instance, an assortment of medium blues, greens and purples for the MEDIUM and an assortment of dark blues and greens for the DARK.) Don't worry too much about your fabrics; remember, much of the charm of a scrap quilt lies in its unstudied variety!

A SCRAPPY SURPRISE--STEP 1: CUTTING

You'll need: Rotary cutter, cutting mat, long cutting ruler with 1/8 inch markings, 6 inch or 8 inch cutting square with 1/8 inch markings

READ ALL OF THE CUTTING INSTRUCTION BEFORE YOU BEGIN

1. Cut 2 strips, 2 7/8 ins x about 44 ins, from each of FOUR of the ten LIGHT prints. You will have a total of 8 light strips. Subcut the strips into 96 squares, 2 7/8 ins. x 2 7/8 ins.. Divide the squares on the diagonal to yield 192 half-square triangles
2. Cut 3 strips, 2 1/2 ins. x about 44 ins., from EACH of the six remaining LIGHT prints. You will have a total of 18 light strips. Subcut SIX of these strips (one of each of the six different fabrics) into 96 squares, 2 1/2 ins. x 2 1/2 ins.
3. Cut 3 strips, 2 1/2 ins. x about 44 ins. from EACH of the six MEDIUM prints. You will have a total of 18 strips. Subcut SIX of these strips (one of each of the six fabrics) into 96 squares, 2 1/2 ins. x 2 1/2 ins.
4. Cut 2 strips 2 7/8 ins. x about 44 ins. from EACH of the four dark prints. You will have a total of 8 dark strips. Subcut the strips into 96 squares, 2 7/8 ins. x 2 7/8 ins. Divide the squares on the diagonal to yield 192 half-square triangles.

WATCH FOR STEP 2 NEXT MONTH!

MYSTERY! A SCRAPPY SURPRISE

(Barbara Black)

Part 2 of 6

written by Judy Hopkins and reproduced with permission of the author.

STEP 2: PIECING

Machine piecing is recommended. Use 1/4 inch seam allowance.

1. Join the remaining 12 2 1/2 ins. x about 44 ins. LIGHT and MEDIUM strips that you cut last month to make 12 strip units that look like this:
2. Combine the fabrics at random. The strip units should measure 4 1/2 in. wide when sewn. Press seams toward the MEDIUM print.
3. Subcut the strip units into 192 segments, 2 1/2 ins. wide:

WATCH FOR STEP 3 NEXT MONTH!

MYSTERY! A SCRAPPY SURPRISE

(Barbara Black)

Part 3 of 6

written by Judy Hopkins and reproduced with permission of the author.

A SCRAPPY SURPRISE--STEP 3: MORE PIECING

1. Join the 2 1/2 ins. segments you cut in Step 2 to make 96 four patches. Combine the fabrics at random.

WATCH FOR STEP 4 NEXT MONTH!

MYSTERY! A SCRAPPY SURPRISE

(Barbara Black)

(written by Judy Hopkins and reproduced with permission of the author)

A SCRAPPY SURPRISE--STEP 4: EVEN MORE PIECING 1. Join the $2 \frac{7}{8}$ ins. LIGHT and DARK half-square triangles to make 192 units. Combine the fabrics at random.

WATCH FOR STEP 5 NEXT MONTH!

MYSTERY! A SCRAPPY SURPRISE

Part 5 of 6

Written by Judy Hopkins and reproduced with permission of the author

A SCRAPPY SURPRISE - STEP 5: LOTS OF PIECING

Join the half-square triangle units you made in Step 4 with the 2-1/2" LIGHT and MEDIUM squares to make 96 units that look like this:

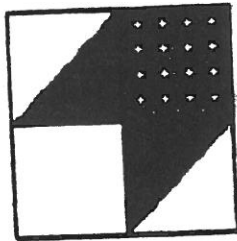

Combine the fabrics at random.

WATCH FOR THE LAST STEP NEXT MONTH!

CHECKLIST - JANUARY 1994

- Nametag
- Charm Square Packets
- Show & Tell Treasures
- Raffle Money/Donations
- Old Phone Books and/or boxes of Kleenex
- Secret Pal Gifts & Thank You
- Overdue Library Books
- Other _____

Jan. 1994

MYSTERY! A SCRAPPY SURPRISE

Part 6 of 6

Written by Judy Hopkins & reproduced by permission of the author.

Step 6: PUTTING IT ALL TOGETHER

1. Join the four-patches you made in Step 3 and the units you made in Step 5 to make 48 traditional Road to Oklahoma blocks (see fig. 1.) Combine the fabrics at random. Note that some of the units are turned differently than they were when you made them.
2. Set the blocks together, 6 across and 8 down, as shown, turning every other block to form a pattern of stars and chains. Fig. 2 shows half the quilt. Duplicate and attach to bottom if graphic is to show entire quilt.

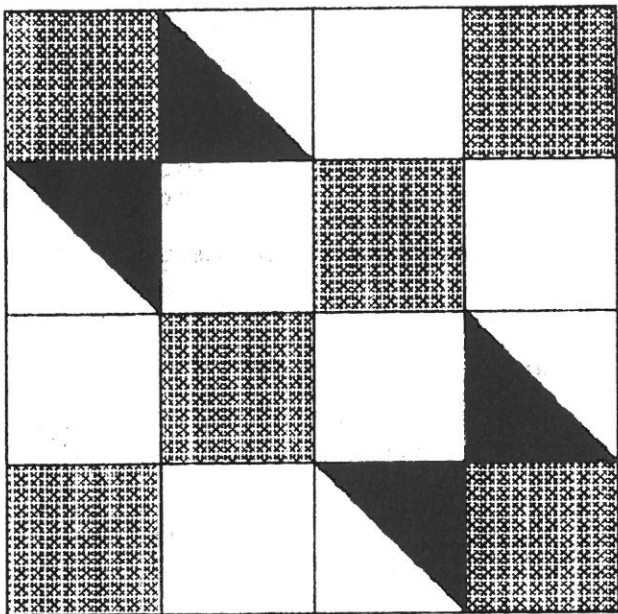

FIG. 1

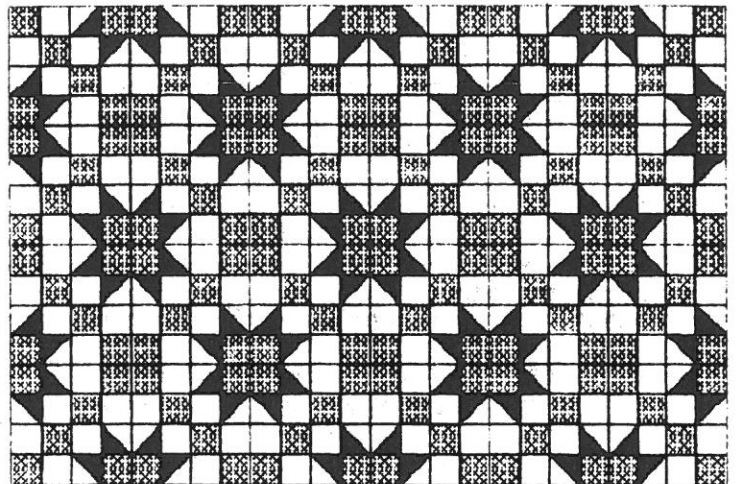

FIG. 2

3. Add 6" borders in your choice of fabric. 1 1/2 yards will yield 8 strips, 6 1/2" x about 44", for seamed borders. For borders cut from the lengthwise grain, you will need 1 3/4 yds of fabric. Measure your quilt top across the top, middle and bottom in both directions. Find the average of the length and cut two side borders to that size. Add side borders first, measuring from the middle out. Press sides out and measure width of the quilt across the top, middle, and bottom. Find the average width and cut two borders to that size. Add top and bottom borders, again measuring from the middle out. This will help ensure a smooth top.

4. Press, baste, quilt as desired, and bind. Be sure to sign and date your quilt somewhere!

HQH gives a warm "Thank You!" to Barbara Black for the time and energy she put into our Mystery Series Quilt. We hope to see all of your "Scrappy Surprises" at future Show and Tells.

NEW MYSTERYSERIES QUILT BEGINS NEXT MONTH

Those of you keeping up with Barbara Black's Mystery Series Quilt will find the final instructions above. If you are ready to start on a new series quilt after the bustle of the holidays, Carol Strong has put together something to keep you busy for the next six months, beginning in our March newsletter. She has combined strip-, foundation-, and hand-piecing techniques in an attractive quilt with four different fan patterns set together with traditional Jacob's ladder blocks. At the guild meeting in January, Carol shared with us the fabric list and the quilt layout to get us thinking about our own color scheme. She told us, "I'll bet no one will choose my colors!" Are you ready to take that bet?

Feb. 1994